

# CHEMICAL ENGINEERING WORLD

www.jasubhaimedia.com

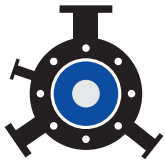

**PTFE LINED SYSTEMS**  
VALVES | PIPES | FITTINGS | COATINGS

www.ptfeindia.com

| PTFE | PFA | FEP | ETFE  
| PVDF | ECTFE | PP | HDPE



**APPLICATOR**

a Global Trusted Brand

**YOUR SUSTAINABLE BUSINESS PARTNER  
IN FLUOROPOLYMER LINED PRODUCTS SINCE 1994**



Material options available on customer request from world renowned fluoropolymer suppliers



**HI-TECH APPLICATOR**

1102-B, Phase-3, G.I.D.C. Ind. Estate, Vatva, Ahmedabad - 382 445, Gujarat - India.  
+91 79 4030 7621 / 2583 3040 / 2589 1740 | +91 97370 46491 | hitech@ptfeindia.com



\*HI-TECH OVAL LOGO, PTFE LINED SYSTEMS & FLUOROHIT ARE REGISTERED TRADEMARK OF HI-TECH APPLICATOR



**MIST RESSONANCE  
ENGINEERING PVT. LTD.**



LEADING  
**COOLING TOWER  
SPECIALISTS**  
SINCE 1990



**MODEL - I**

**LOUVER TYPE MIST COOLING SYSTEM**

*(Guaranteed approach of 1°C to design WBT)*

- Close Approach to WBT ensuring huge process benefits
- FAN-LESS, FILL-LESS Design
- Maintenance free Operation due to Choke-less design of Nozzles.
- Rugged structure with HDGI MOC & FRP casing, Saran3 PVC Nozzles, ensuring a life of 15 years plus.

**MODEL - II**

**INDUCED DRAFT MIST COOLING TOWER**

*(Fill-Less Technology)*

- Approach to 3°C to design WBT with temperature drop up to 15°C.
- Direct saving of 30 to 50% on Fan Power due to low pressure drop across the Tower.
- Maintenance free operation due to absence of Fills even for contaminated water application.
- Rugged structure with pultruded FRP/HDGI MOC with FRP casing & Stainless Steel 304 Nozzles, ensuring a life of 15 years plus.



explore more

\*Copyright © 2026, MREPL, All rights reserved

📍 1304/04, 'Anandi', Bajirao Road, Pune, India  
☎ +91-89569 94718 / +91 20-2447 2726

✉ mistcreation@gmail.com  
🌐 www.mistcreation.com



500+ Clients



30+ Years of Operation

# CHEMICAL ENGINEERING WORLD

[www.jasubhaimedia.com](http://www.jasubhaimedia.com)

## Environment





**sealmatic®**

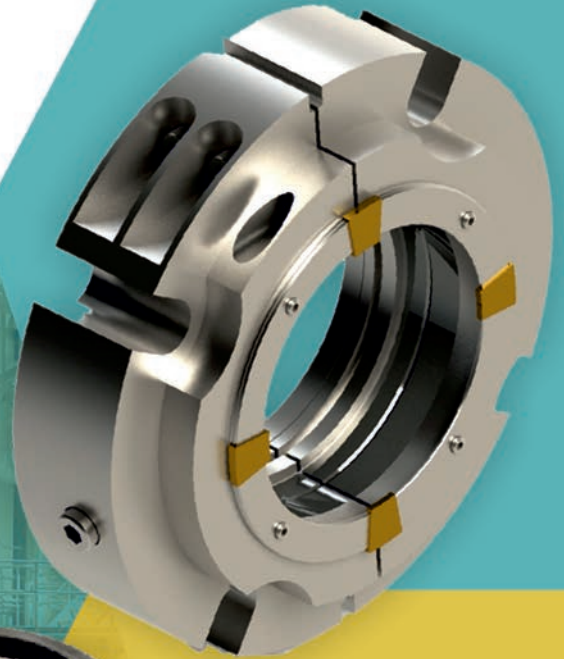

# MECHANICAL SEALS

Oil & Gas  
Refinery  
Petrochemical  
Chemical  
Power

Fertiliser  
Pharmaceutical  
Paper  
Aerospace  
Marine

**Sealmatic India Ltd.**

Bldg A, Indiplex IV, Survey No-12, Hissa No-9A,  
Village Ghodbunder, Shanti Vidya Nagri Road,  
Mira Road (E). Thane - 401104. India.

T : +91 22 50502700  
E : info@sealmaticindia.com



CE II 3 G/D c T2  
ATEX - 2014/34/EU



ISO 9001:2008  
ISO 14001:2004  
BS-OHSAS 18001:2007



[sealmaticindia.com](http://sealmaticindia.com)

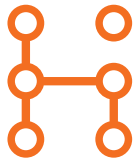

HORIZON  
POLYMER

[www.horizonpolymer.com](http://www.horizonpolymer.com)

# India's Largest Processor of FLUOROPOLYMERS



Valves qualified  
ISO 15848-Part 1.



Pipework qualified  
ASTM F 1545



Chemours Co FC LLC - Delaware appoints Horizon Polymer as TEFLON® Licensing Partner for India Under Trademark license agreement to promote and sell PTFE/PFA/FEP Lined Piping products using TEFLON® PTFE/PFA/FEP Fluoropolymer.

TEFLON and Teflon diamond brand logo are registered trademarks of The Chemours Company FC, LLC used under license by Horizon Polymer Engineering Pvt. Ltd.

**Horizon Polymer Eng Pvt. Ltd.:**

204, Sumer Kendra, Pandurang Bhudhkar Marg, Worli, Mumbai - 400018. India

Contact: +91 22 24965031-36 | Fax: +91 22 24961073

Email: [vp@horizonpolymers.com](mailto:vp@horizonpolymers.com)



**CHEMICAL ENGINEERING WORLD**  
RNI REGISTRATION NO. 11403/1966

**CHAIRMAN**

Maulik Jasubhai Shah

**PUBLISHER & CEO**

Hemant Krishna Shetty

**EDITOR**

Hemant Krishna Shetty

**DEPUTY EDITOR**

Reshmi Menon

**CREATIVES**

Arun Parab

**GENERAL MANAGER SALES**

Prashant Koshti

Amit Bhalerao

**BRAND MANAGER**

Sudhanshu Nagar

**SALES**

Godfrey Lobo

Chandrabhas M Amin

Yonack Pradeep

The Publishers and the Editors do not necessarily individually or collectively identify themselves with all the views expressed in this journal. All rights reserved. Reproduction in whole or in part is strictly prohibited without written permission from the Publishers.

Single Copy Price: ₹ 150/-

Annual Subscription: ₹ 1620/-, Foreign: USD 180

**Registered Office:** 26, Maker Chambers VI, 2nd Floor,  
Nariman Point, Mumbai 400 021, INDIA.

Tel.: 022-4037 3737 Fax: 022-2287 0502

**E-mail:** sales@jasubhai.com

**PLACE OF PUBLICATION**

**JASUBHAI MEDIA PVT. LTD.**

210, Taj Building, 3<sup>rd</sup> Floor, Dr. D. N. Road, Fort,  
Mumbai 400 001, Tel: +91-22-4037 3636

**Published by Mr Hemant K. Shetty**

Address: 406-D, The Karachi Citizens Co-Op Hsg Soc Ltd.,  
Juhu Varsova Link Road, Andheri West, Mumbai - 400053.

**Printer: Harilal Gangaji Patel**

**Printing Press (Name & Address): The Great Art Printers**

25, Unique House, S A Brelvi Road, Fort, Mumbai 400 001.

**Published from Jasubhai Media Pvt .Ltd.** 3<sup>rd</sup> Floor, Taj Building,  
210, Dr. D N Road, Fort, Mumbai 400 001.

# CHEMICAL ENGINEERING WORLD

## AD INDEX

Aeron Composite Limited.....	9
Dip-Flon Engineering & Co.....	Back Cover Page
Hi-Tech Applicator .....	1
Horizon Polymer Engineering Pvt Ltd .....	5
Mist Ressonance Engineering Pvt Ltd .....	2
Nickel Alloy Corporation .....	11
Power Build Pvt. Ltd.....	13
Scientific Research Instruments Company Pvt. Ltd .....	15
Sealmatic India Ltd .....	4
Transflow Process Systems Pvt. Ltd.....	7
Vinodrai Engineers Pvt. Ltd. ....	15

Published by:





**Transflow**  
 PROCESS SYSTEMS PVT LTD  
 (An ISO 9001 : 2015 Certified Company)

**25**  
 Years

**Excellence In  
 Fluoropolymer  
 Processing**

◆ We offer advanced corrosion-resistant solutions using high-performance fluoropolymer lining technology, All our lined products are 100% quality assured & manufactured using advanced specialized paste extrusion technology. Our fluoropolymer linings are designed and executed according to ASTM F1545-15a standards, suitable for full vacuum applications, delivering exceptional service life, chemical resistance, and mechanical stability even under extreme operating conditions.

 **Designation: F1545-15a**



◆ Our products are successfully operating in highly hazardous and corrosive chemical services, including: Hydrofluoric Acid (HF) applications, Bromine and brominated chemical, Electrolyte and battery chemical, Inorganic and fluorine, Specialty and fine chemicals, Dyes & Pigments. widely used in agrochemical manufacturing such as: Pesticide and insecticide, Herbicide and fungicide, Fertilizer intermediates acids, Chlorinated and fluorinated, Solvent recovery and chemical transfer systems.

<b>Renowned Fluoropolymer Material Options</b>	 <b>Chemours™</b>	 <b>GFL</b> <small>GUJARAT FLUORO-CHEMICALS        VALUE THROUGH GREEN CHEMISTRY</small>	<b>ACCREDITATIONS</b>  <b>ISO</b> <small>9001:2015</small>	 <b>ISO</b> <small>14001:2015</small>	 <b>ISO</b> <small>45001:2018</small>
	 <b>SOLVAY</b>	 <b>DAIKIN</b>			
<b>Email</b> <a href="mailto:sales@transflow.in">sales@transflow.in</a> <a href="mailto:mktg@transflow.in">mktg@transflow.in</a>	<b>Website</b> <a href="http://www.transflow.in">www.transflow.in</a>			 <b>TOYO ENGINEERING</b>	 <b>ASTM INTERNATIONAL</b>
<b>Unit-1</b> Sarvodaya Estate, At: Khatamba, PO: Ankhol, Tal: Waghodia, Dist Vadodara - 390019,	<b>Unit-2</b> 3/2, Ganesh Industrial Estate, New VIP Ring Road, Near Raghukul School Lane, Vadodara - 390019				

# CONTENTS

## GUEST COLUMN

**Bridging Bharat & India: How Digital Engineering Solutions are Narrowing Urban-Rural Economic Divide** 45



**Mr. Nagendra Nath Sinha**  
Managing Director  
Rodoc Digital & Advisory

## INTERVIEW

**"Safety has definitely been on an upward trajectory!"** 34



**Mr. Viraj Shah**  
Founder  
Swa Consultancy Pvt. Ltd.

## NEWS FEATURE

**Showcasing the Future of Smart Manufacturing at B&R Innovations Day 2026** 41



**Hindalco announces ₹21,000-crore smelter expansion; commissions FRP and battery foil facilities in Odisha** 42

**Henkel and Rotary give PoP Ganesha idols a second life through project HARMONY** 44



## CHEMTECH WORLD EXPO 2026 26



SPECIAL REPORT

## BUDGET 2026-27 30



## IMPACT FEATURE

**How A.T.E. HUBER is Future-Proofing the Chemical Industry** 24



 **Engineering a Complete Power Transmission Ecosystem: Power Build's Full Product Spectrum** 36



**Durr CTS Innovative Air Abatement Solutions for Chemical and Pharmaceutical Industries** 38

**Vacuum Technology for Chemical and Pharmaceutical Processes** 48



**Ms. Meike Strasheim**  
Head of Market Management Content Strategy  
Pfeiffer Vacuum+Fab Solutions

## NEWS 10

More than  
**800+**  
Satisfied  
Clients

**CORROSION FREE  
COMPOSITE SOLUTIONS**

## Save Project Costs Without Compromising Strength



**FRP CABLE  
MANAGEMENT SYSTEMS**



**FRP GRATINGS**



**FRP HANDRAIL**



**FRP REBAR**



**FRP TANK**



**FRP CUSTOM SOLUTIONS**



**FRP TRENCH COVER**

Approved with all major consultants and EPC Contractors  
for Chemical and Process Plants



Corrosion/Chemical  
Resistance



High Strength



Light Weight



Electrical Non  
Conductivity



Thermal Non  
Conductivity



Ease of  
Fabrication



Low Life Cycle  
Cost



Sustainable



Flame Retardant

**MANUFACTURER OF FIBERGLASS / FRP / GRP**

Cable Trays | Gratings | Structural Profiles | Ladders | Pitt Cover | Crossovers | Fencing  
Handrails | Staircases & Platforms | Safety Marker Line | Cable Cleats | FRP Rebar | FRP Tank



**AERON COMPOSITE LIMITED**

Survey No. 170 to 174, Jornang - Akhraj Road, Via Ambaliyasan,  
Jornang, Dist. - Mehsana, Gujarat - 382732 (INDIA)

T : +91-99099 88266, +91-90331 58500 | F : +91-79-26561238

E : info@aeroncomposite.com | W : www.aeroncomposite.com

**Dealers & Distributors Inquiry Solicited**

## Economic Survey 2025-26 highlights steady growth of chemicals and petrochemicals sector

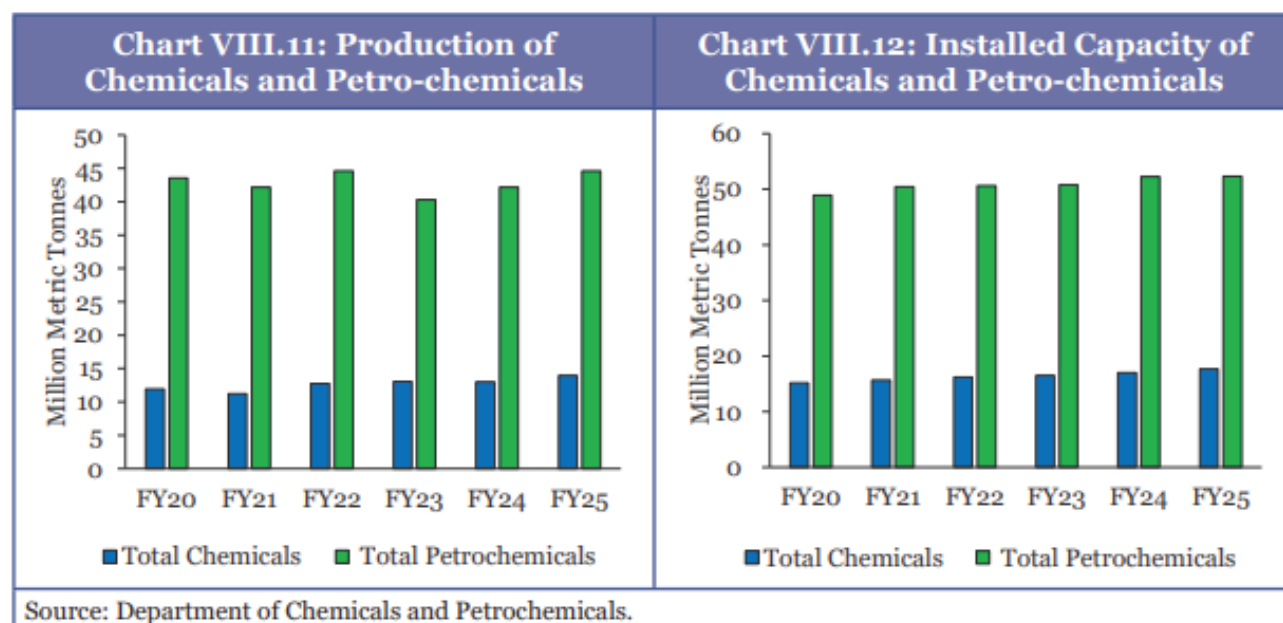

**New Delhi:** The Chemicals and Petrochemicals sector continues to play a significant role in the industrial development of the Indian economy, with strong backward linkages to petroleum refining and natural gas processing and forward linkages with several downstream industries.

As highlighted in the Economic Survey 2025-26, the sector contributed 8.1 per cent to the overall manufacturing sector's Gross Value Added (GVA) in Financial Year 2024.

The Economic Survey further notes a consistent upward trend in the production of selected major chemicals and

petrochemicals over the last decade. Total production increased from 45,638 thousand metric tonnes (MT) in FY16 to 58,617 thousand MT in FY 25, registering a Compound Annual Growth Rate (CAGR) of 2.8 per cent during FY16-FY25.

(Note: Department of Chemicals and Petrochemicals monitors selected Major Chemicals and Petrochemicals products only. The data source in respect of Installed Capacity and Production of Chemical products is Monthly Production Reports (MPRs) received from the chemical manufactures under large and medium scale units only.)

## BASF to open global Digital Hub in Hyderabad, India

**Hyderabad, India:** BASF plans to open a global Digital Hub in Hyderabad in the first quarter of 2026, sharpening BASF's existing global Digital Hub network in Europe (Ludwigshafen and Madrid) and Asia Pacific (Kuala Lumpur). Digital Hubs are centers of digital expertise that deliver standardized, digital services at scale to BASF's businesses worldwide. "With this next step in value creation in BASF's back-end organization, we ensure digital service delivery on competitive terms," said Dr. Dirk Elvermann, Chief Financial Officer and Chief Digital Officer, BASF SE. "Hyderabad offers

all the attributes of a state-of-the-art Digital Hub with global reach. Seamless cooperation between the new Digital Hub in India and our existing global Digital Hubs, and excellent service delivery to our businesses, are the top priorities."

Another pillar to reduce complexity and cost is to standardize and focus the digital portfolio on areas that generate the greatest value for BASF's core businesses. This will be accompanied by structural changes. Overall, the division Global Digital Services aims to significantly reduce its global workforce by 2030. This includes positions in Ludwigshafen. Furthermore, Global Digital Services plans to reduce the overall number of sites at

# NICKEL ALLOY CORPORATION

ISO 9001 : 2015 CERTIFIED



## LEADING IMPORTERS, STOCKIST AND SUPPLIERS OF

- NICKEL ALLOYS
- MONEL 400 / K-500
- HASTELLOY C-276
- HASTELLOY C-22
- ALLOY 20
- SMO 254
- TITANIUM GR 2 & 5
- SPECIAL ALLOYS
- INCONEL 625
- INCONEL 600
- INCONEL 825
- INCONEL 718
- SUPER DUPLEX
- SS 904L

Contact : Mukesh Sanghvi : +91-9819144888

Email : [sales@nickelalloycorp.com](mailto:sales@nickelalloycorp.com) • Web : [www.nickelalloycorp.com](http://www.nickelalloycorp.com)

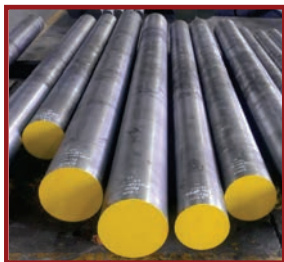

ROUND BAR



RING



CIRCLE



RING



FLANGES



NUT BOLT



PLATE



PIPES



SQUARE-HEX  
BARS

• NICKEL ALLOYS  
**SUPERIOR  
QUALITY**

• SPECIAL ALLOYS  
**QUICK  
AVAILABILITY**

• TITANIUM ALLOYS  
**GLOBAL  
SUPPLY**

• DUPLEX & SUPER DUPLEX  
• HIGH PERFORMANCE ALLOYS  
**PROFESSIONAL  
TEAM**

79 / 81, WEST VIEW BUILDING-A, GROUND FLOOR, SHOP NO. 1-A,  
10TH KHEDWADI LANE, MUMBAI - 400 004. INDIA

which digital specialists are located. All measures will be implemented in a socially responsible manner and in compliance with existing co-determination rights.

“The Digital Hub in Hyderabad becomes part of BASF’s long-standing and successful presence in India with existing manufacturing and research and development activities in the country. It supports BASF’s ambition to work faster, leaner and focus on what creates the most value,” said Alexander Gerding, Head of BASF Group Companies in India.

## Teknovace partners with Remmers to build global wood coatings manufacturing hub in India



**Mumbai:** Teknovace, one of India’s fastest-growing premium wood coatings companies, has entered into a strategic global partnership with Remmers Gruppe SE, an independent, family-owned German leader in speciality construction chemicals and high-performance wood coatings. As part of this partnership, Remmers plan to make a ₹300 crore strategic equity investment in Teknovace to acquire a 50.01 per cent stake in two tranches.

The strategic investment comes at a time when India’s wood coatings market — valued at approximately USD 1.3 billion (₹10,000 crore) — is projected to grow at 11 per cent annually, driven by rising demand for premium

furniture, interior finishes, and sustainable materials.

Founded in 2019, Teknovace has rapidly emerged as a strong domestic challenger in the premium wood coatings segment, delivering a 43 per cent annual average growth rate since inception, far outpacing the broader paints and coatings industry. The company recorded revenues of 57.1 crore in FY25, operates two manufacturing facilities with a current capacity of 6,000 tonnes per annum, and serves customers through a nationwide network of branches and dealers. Remmers, founded in 1949, operates across more than 30 countries and brings over 75 years of global expertise in advanced coatings, construction chemicals, and material science.

The capital infusion will be deployed to significantly expand Teknovace’s manufacturing and technology capabilities. This includes scaling wood coatings production capacity from 6,000 tonnes to 60,000 tonnes per annum, setting up an integrated UV coatings manufacturing facility, establishing an in-house resin manufacturing unit, and building a greenfield construction chemicals factory in India. The partnership also envisages the creation of a global R&D centre in India, combining Remmers’ advanced technology platforms with Teknovace’s R&D-led manufacturing expertise.

Beyond domestic growth, the alliance is designed to position India as a global manufacturing and export hub for advanced coatings. Teknovace will directly supply markets across Asia-Pacific, the Middle East, and Africa, while also acting as a manufacturing and sourcing partner for select global markets through Remmers’ international network.

## Enlight Metals expands into chemicals sector with new subsidiary, Enlight TradeHub Pvt. Ltd.



Vedant Goel, CEO & Co-founder of Enlight Metals

**New Delhi:** Enlight Metals Pvt. Ltd., India’s leading AI-driven metal aggregator, has announced its expansion into the chemical trading market with the launch of its new subsidiary, Enlight TradeHub Pvt. Ltd. The new division focuses on trading

# Build it, your way.

With our customizable  
range of Series M  
Helical Inline  
Geared Motors.



**Series M -**  
Helical Inline  
Geared Motor



**Series F -**  
Parallel Shaft Mounted  
Geared Motor



**Series K -**  
Right Angle Helical  
Bevel Geared Motor

GEARED MOTORS  
GEAR BOXES  
CUSTOMIZED GEARS  
DRIVE SOLUTIONS

- Robust design • Modular construction • User-friendly interface • Quick installation
- Economical operation • Easy maintenance



Scan for our  
LinkedIn page

**Phone:** +91-2692-231070, 231120, +91-97277-19344 | **Website:** [www.powerbuild.in](http://www.powerbuild.in)  
**CIN:** U32201GJ1972PTC002065 | **E-mail:** [infopbl@powerbuild.in](mailto:infopbl@powerbuild.in)



industrial-grade chemicals such as solvents, acids, and speciality intermediates for sectors including petrochemicals, pharmaceuticals, manufacturing, and agriculture. The business, which began operations in Q3 2025, is scaling nationwide by leveraging Enlight Metals' existing procurement strength and logistics network, with plans to enter regional export markets in the near future.

The chemicals vertical has been built to work closely with the company's core metal aggregation operations, offering customers easier access to a broader range of raw materials under a unified sourcing ecosystem. By combining shared logistics and a common customer base, the company expects stronger operational efficiencies and expanded cross-selling opportunities.

"With Enlight TradeHub, we are strengthening our commitment to building a cohesive, technology-enabled supply ecosystem for industrial India," said Vedant Goel, CEO and Co-founder of Enlight Metals.

Sustainability remains a key priority for the new division, which is focusing on low-emission feedstocks and bio-based alternatives. Enlight TradeHub is also developing a green product line that includes recyclable industrial cleaners scheduled for launch by mid-2026, alongside ongoing initiatives around waste reduction and circular supply chains.

## Dow India recognized as one of India's Best Workplaces™ in Manufacturing 2026 for fourth consecutive year



Siddhartha Ghosal, CEO and Country President of Dow India

**Mumbai:** Dow Chemical International Private Limited (Dow India) has been recognized as one of India's Best Workplaces in Manufacturing – Top 50 Large category, awarded by Great Place to Work®.

This year, 361 organizations participated in a rigorous evaluation process through the Trust Index™ Survey and Culture Audit™. These tools measure quality of employee experience & evaluate the strength of the leadership as supported by meaningful values & philosophy and quality of the

practices & programs that shape employee experience, build consistent levels of trust and enable each individual to use their potential to better organizational performance.

"We are honoured to receive this recognition," said Siddhartha Ghosal, CEO and Country President of Dow India. "Winning this award for the fourth consecutive year is a testament to our sustained commitment to building resilient operations. It also reflects the strength of our culture — one where every employee is empowered to thrive and contribute to our collective success."

This recognition reaffirms Dow India's prominence as one of the Best Workplaces in Manufacturing and reflects the company's unwavering commitment to building an equitable, inclusive, and employee centric culture. Through focused initiatives that champion continuous learning, skills enhancement, and personal development, Dow India continues to cultivate a workplace environment where employees feel empowered to excel and contribute meaningfully to the organization's success.

## REnergy Dynamics delivers India's fastest CBG plant to achieve 21+ TPD capacity



India's fastest CBG plant to achieve 21+ TPD capacity

**New Delhi:** REnergy Dynamics (RED) has announced that its Compressed Biogas (CBG) plant in Nagothane, Maharashtra has become the fastest CBG plant India to cross its nameplate capacity of more than 21 tons per day (TPD). This milestone makes it the only plant in India to have achieved its capacity in less than 24 months. Additionally, it is only the second industrial scale multi-feedstock plant in India to achieve full nameplate production.



# Rotolining Machines

Seamless Corrosion Protection,  
reactors, pipeline, fittings & process vessels.

LDPE, HDPE, PFA, ETFE, PVDF, PTFE

Complete range of Standard  
as well as custom designed  
Rotolining Machines  
from 200 to 8000 kg vessels.



[www.vinodrai.com](http://www.vinodrai.com)



+91-9049113377



VALEGRO



## Recirculating Coolers/chillers

- Working temperature range : -20 to +85 °C
- Temperature stability:  $\pm 0.3$  to  $\pm 0.2$  °C
- Cooling capacity: 0.35 to 2.5 kW
- Heating Capacity: 2 kW
- Pump flow rate: 15 to 40 lpm
- Pump pressure: 0.5 to 3.5 bar



## Scientific Research Instruments Company Private Limited

Website: [www.srico-labworld.com](http://www.srico-labworld.com) | Telephone: +91 9900674407 | Email: [info@srico-labworld.com](mailto:info@srico-labworld.com)

Bengaluru | Mumbai | Hyderabad | Bhubaneswar | Vadodara | Delhi

Chennai | Goa | Thiruvananthapuram | Pune | Visakhapatnam | Kolkata | Guwahati | Ahmedabad | Chandigarh | Lucknow

Visit our Website



RED's scope for the project included technology, EPC and operations for one of India's largest conglomerates. Achieving stable, full-scale operations at a CBG plant of this size is rare in the current bioenergy ecosystem. The Nagothane facility represents an important step forward for India's CBG and bioenergy sector, reinforcing confidence in the scalability and long-term viability of large bioenergy projects when designed and executed with rigor.

The Nagothane plant is engineered to process a diversified mix of feedstocks including napier grass,

press mud cake, cow dung, paddy straw, bagasse and cane trash. This multi feedstock capability enhances operational flexibility and ensures stable year-round performance.

It integrates an advanced membrane-based gas upgrading system capable of delivering biomethane purity of up to 99 per cent when required, with high methane recovery efficiency that maximises yield and strengthens plant economics.

## Hindalco, KADA partner to strengthen youth employability with multi-skills training centre at Kuppam



Shri N. Chandrababu Naidu, Chief Minister of Andhra Pradesh, inaugurates Hindalco's state-of-the-art Multi-Skills Training Centre at its Kuppam plant in Andhra Pradesh.

**Andhra Pradesh:** Hindalco Industries Ltd, in collaboration with the Kuppam Area Development Authority (KADA), has launched a state-of-the-art Multi-Skills Training Centre at its Kuppam plant in Andhra Pradesh.

The facility was inaugurated by Hon'ble Shri N. Chandrababu Naidu, Chief Minister of Andhra Pradesh, in the presence of senior Hindalco leadership, including Mr. Samik Basu, Chief Human Resources Officer, Ms. Kopal Agarwal, Head - Downstream, and other dignitaries.

The Kuppam Multi-Skills Training Centre aims to train and upskill over 500 youth annually through placement-linked, industry-aligned programmes, benchmarked to national and global standards. The initiative represents a scalable public-private partnership designed to accelerate regional transformation and advance the objectives of the Swarna Kuppam Vision 2029.

Speaking at the inauguration, Mr. Samik Basu, Chief Human Resources Officer, Hindalco Industries Limited, added, "This Centre brings together global innovation and local relevance leveraging immersive, AI-enabled learning in partnership with Eon Reality, USA to make

world-class vocational training accessible to youth in their own language.”

Spread across 22,500 sq. ft., the purpose-built facility includes smart classrooms, domain-specific practical labs, digital learning labs, and career guidance infrastructure, designed to deliver industry-relevant, outcome-driven skilling.

Over the next three years, the Centre is expected to train over 875 youth and facilitate up to 600 job placements, while indirectly benefiting more than 5,000 family members and engaging 20,000 community members through awareness and skilling initiatives.

A key differentiator of the Centre is its AI-enabled digital learning platform, accessible even on basic smartphones and offering lifetime access for learners to upgrade skills and solve real-world challenges. Courses are delivered in local languages including Telugu, Gujarati, and Odia, ensuring inclusivity and ease of learning. This model will be replicated across Hindalco-supported centres in Gujarat and Odisha.

The initiative is strengthened through partnerships with leading industry players such as Philips Learning, Max Healthcare, SkillSonic, Indian Institute of Welding, Fronius, Seabery, and NASSCOM, with NASSCOM certification for select programmes in AI, data analytics, and cybersecurity.

The Kuppam Centre is part of Hindalco’s Youth Employability Enhancement Initiative, which has enabled sustainable livelihoods for over 12,000 youth across India, with centres such as Sambalpur, Dahej, and Rayagada emerging as strong models of impact. ■

# CHEMICAL ENGINEERING WORLD

Dynamic Platform to Connect with  
Chemical Industry Ecosystem

Direct Reach to  
**>200,000 Readers** across  
**>50 countries** in  
**Print** and **Digital Version**



**UPCOMING ISSUE - MARCH 2026**

## Surface Engineering Coating & Corrosion Control

The Surface Engineering sector is evolving with introduction of new and advanced technologies. With companies gearing up to achieve net zero goals, there are new strategies and implementation is on rise of advanced technologies, to combat corrosion.

The March 2026 edition of *Chemical Engineering World* is a special issue on Surface Engineering & Corrosion Control. It will feature latest trends, technologies, research and development focused articles.

Besides, it will also feature our regular columns such as News, Project Updates, Impact Feature, Products and Chemtech 2026 photo feature. Send Editorial submissions before **18<sup>th</sup> March 2026** to [editorial@jasubhai.com](mailto:editorial@jasubhai.com)

Contact: +91-22-4037 3636,  
Email: [sales@jasubhai.com](mailto:sales@jasubhai.com)  
Website: [www.jasubhaimedia.com](http://www.jasubhaimedia.com)



### Department of Fertilizers seeks youth perspectives to promote balanced use of fertilizers



**New Delhi:** In a significant step towards strengthening participatory governance and promoting sustainable agriculture, the Department of Fertilizers has intensified its efforts to address the growing challenge of soil degradation across the country. Shri Rajat Kumar Mishra, Secretary (Fertilizers), recently conducted a detailed virtual interaction with nearly 100 agriculture graduates from different parts of the country, currently serving in Hindustan Urvarak & Rasayan Limited (HURL) and Rashtriya Chemicals and Fertilizers Limited (RCF).

The interaction focused on addressing the adverse impact of excessive and imbalanced use of urea, which has contributed to critical nutrient deficiencies, declining soil carbon levels, and overall deterioration of soil health in several regions. The Secretary emphasized the urgent need to promote balanced fertilization practices, encourage integrated nutrient management, and strengthen awareness at the grassroots level to restore soil vitality and ensure long-term agricultural sustainability.

By directly engaging with these young agricultural professionals — who are closely connected with farmers and field-level operations — the Department seeks to bridge the gap between policy formulation and ground realities. The initiative aims to incorporate practical feedback, field experiences, and innovative suggestions into policy implementation, thereby

ensuring that national objectives on balanced fertilizer use are effectively translated into action at the farm level.

Addressing the participants, the Secretary emphasized that youth engagement is crucial for India's agricultural transformation. He noted that while the government ensures the availability of fertilizers, the focus must shift to preventing soil damage caused by excessive use. The session also addressed the physical degradation of soil, specifically the increasing hardness and decreasing carbon content resulting from chemical over-dependence. The Secretary encouraged graduates to document success stories of farmers shifting to organic farming and to promote the use of compost and green manure. He noted that while resources like vermicompost are available through various schemes, a lack of information often hinders adoption. The Secretary suggested that these sustainable practices could be scaled in collaboration with Lakhpati Didis, self-help groups, and community organizations.

Specific field experiments were also discussed, such as those conducted by Awadhesh Singh in Gorakhpur, which demonstrated that balanced phosphate use leads to increased yields and better soil structure. The session, also attended by the Additional Secretary and Joint Secretary, CMD and MD from HURL and RCF concluded with a reaffirmation of the Department's commitment to scientific nutrient management.

## Eight Padma Awardee progressive farmers lead national dialogue on balanced fertilizer use



In a unique first-of-its-kind initiative, the Department of Fertilizers organised a high-level brainstorming session today at Shastri Bhawan to strengthen soil health and promote balanced and responsible fertilizer use as a nationwide movement.

The initiative aligns with the vision of Prime Minister Narendra Modi under the "Save Mother Earth" call and the leadership of Union Minister for Ministry of Chemicals and Fertilizers Jagat Prakash Nadda.

The meeting was chaired by Secretary, Department of Fertilizers, Shri Rajat Kumar Mishra, and witnessed participation from Padma award-winning progressive farmers and agricultural experts from across the country.

Welcoming the participants, Mishra said their presence and guidance would provide valuable direction to the Department. He emphasised that ensuring timely and accurate information reaches farmers is crucial to protecting soil health and added that expert recommendations could be implemented as pilot projects to take concrete steps towards balanced fertilizer usage. During his interaction with the

awardees, he underlined the deterioration of soil health over time due to imbalanced fertilizer use.

The meeting concluded with consensus that balanced fertilizer use, promotion of organic and natural farming, and sustained farmer awareness campaigns are essential to safeguarding soil health and protecting Mother Earth. The Department assured it would positively consider and take forward the recommendations received during the session.

The meeting was attended by Additional Secretary Aparna S Sharma, Joint Secretary Krishna Kant Pathak, Joint Secretary Anurag Rohatagi, Deputy Secretary Amar Kushwaha, Deputy Director Gori Shankar, and other officials of the Department.

### India scales new heights in fertilizer self-reliance: P&K production hits historic 15.76 LMT in January

**New Delhi:** In a landmark achievement for India's agricultural sector, the domestic production of Phosphatic and Potassic (P&K) fertilizers —specifically DAP and NPKs — has surged to a record high of 15.76 lakh metric tonnes (LMT) in January 2026. This milestone represents the highest-ever monthly production recorded in the country, signaling a decisive shift toward a self-reliant fertilizer economy.

The Department of Fertilizers under Ministry of Chemicals and Fertilizers attributed this historic spike to the government's visionary and industry-friendly policies. A combination of strategic structural reforms and investment-incentive measures has led to a significant expansion in production capacity across both private and public sectors.

To insulate domestic production from global market volatility and logistical bottlenecks, the government has secured long-term supply agreements with resource-

rich nations. These international pacts ensure an uninterrupted flow of raw materials, allowing domestic units to function at peak efficiency.

Key to this production boom is the effective implementation of the Nutrient Based Subsidy (NBS) policy. By ensuring the timely payment of subsidies, the government has provided essential financial stability to manufacturing companies. This fiscal discipline allows producers to maintain effective control over costs while incentivizing the expansion of existing units and the establishment of new plants.

This surge in production not only bolsters India's food security by ensuring timely availability of fertilizers for farmers but also marks a giant leap in the nation's journey toward becoming an "Aatmanirbhar" (self-reliant) fertilizer powerhouse.

### Fertilizer Subsidy: Government goes fully digital in a landmark reform



**New Delhi:** In line with the Hon'ble Prime Minister Narendra Modi's vision of Digital India and the goal of achieving Viksit Bharat by 2047, the Department of Fertilizers has taken a significant step towards strengthening digital governance and financial reforms. The Hon'ble Union Minister for Health & Family Welfare and Chemicals & Fertilizers Sh. Jagat Prakash Nadda today inaugurated the e-Bill System, which will enable the government to process the fertilizers subsidy of approximately ₹ 2 lakh crores at Kartavya Bhawan in New Delhi. Addressing the event, the Union Minister said that this online system would play a significant role

in strengthening transparent, efficient and technology-driven governance. Secretary Fertilizers, Shri Rajat Kumar Mishra said that the launch marks a major milestone in modernising the Department's financial operations. The newly launched system represents a paradigm shift from manual, paper-based processes to a fully digital, system-to-system workflow, eliminating the need for any physical movement of bills.

This initiative is a significant outcome of the unique technological partnership between iFMS (Integrated Fertilizer Management System) of the Department of Fertilizers and PFMS of the Controller General of Accounts (CGA), Ministry of Finance. The integrated e-Bill system significantly strengthens financial governance, with robust built-in controls that validate payments against predefined criteria, log every action for audit purposes, and reduce the risk of fraud or misuse reinforcing the Government's commitment to transparent, efficient, and technology-driven administration.

Government boosts fertilizer security with record 73% domestic supply in 2025

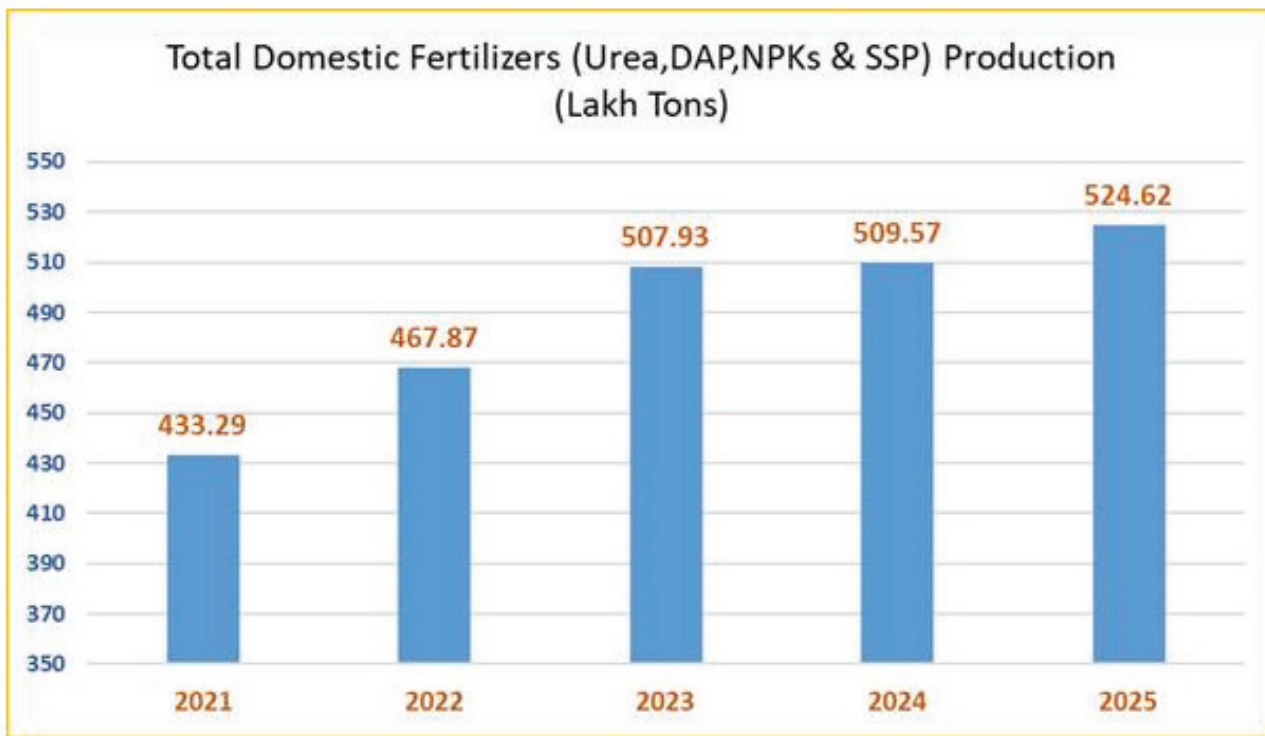

**New Delhi:** Reinforcing the vision of Atmanirbhar Bharat, the Government of India has significantly reduced the country's dependence on fertilizer imports. In 2025, nearly 73 percent of the country's total fertilizer requirement was met through domestic production, representing a significant milestone in achieving self-reliance. The Government continues to work tirelessly to empower farmers, promote self-reliance, and ensure a reliable and uninterrupted supply of fertilizers across the country.

in 2022, followed by a significant jump to 507.93 lakh tonnes in 2023. The upward trend continued in 2024 with production reaching 509.57 lakh tonnes, and further accelerated to an all-time high of 524.62 lakh tonnes in 2025.

With a strong focus on fertilizer security and timely availability of nutrients to farmers, the Government has prioritised long-term supply agreements for key raw materials and adopted a strategy of strategic diversification to safeguard against global uncertainties and supply disruptions.

These sustained efforts have resulted in a steady and consistent rise in domestic fertilizer production over the past five years. Total domestic production of fertilizers, including Urea, DAP, NPKs and SSP has increased from 433.29 lakh tonnes in 2021 to 467.87 lakh tonnes

### DCPC organises farmer training programme at SKUAST-K to promote safe pesticide use and IPM practices



**New Delhi:** Department of Chemicals and Petrochemicals (DCPC) Secretary Ms. Nivedita Shukla Verma has stressed upon safe and regulated pesticide use to ensure agricultural sustainability and food safety.

The Secretary was addressing one-day Farmer Training Programme at Sher-e-Kashmir University of Agricultural Sciences and Technology of Kashmir (SKUAST-K), Srinagar, on 12th January 2026, on the theme "Safe and Judicious Use of Pesticides and Promotion of Integrated Pest Management (IPM) Practices."

The programme was jointly coordinated by HIL (India) Limited and SKUAST-K. The DCPC, secretary appreciated the collaborative efforts of HIL (India) Limited and SKUAST-K, and emphasised farmer training, adoption of IPM practices, and awareness generation as key strategies for reducing pesticide misuse.

The programme witnessed enthusiastic participation of 524 farmers from Srinagar and adjoining districts. A key highlight was the launch of an IPM (Integrated Pest Management) Compendium for regional vegetable crops, aimed at supporting farmers and extension workers. Sixteen Farmer Producer Organisations (FPOs) from the Srinagar region showcased local produce and value-added products, including honey, saffron, apricot-based products, and chillies.

An MoU was signed between HIL (India) Limited and SKUAST-K for the joint implementation of the GEF/UNIDO FARM Project (Financing Agrochemical Reduction and Management) in the Kashmir region.

### UPL announces creation of world's second largest listed pure-play crop protection platform



**Mumbai:** The Board of Directors of UPL Limited has approved a group reorganization plan through a

composite scheme of arrangement with the objective of unlocking value for its shareholders by creation of an independent and focused crop protection platform. The reorganization will consolidate UPL's India and international crop protection businesses through the Scheme, involving UPL and its subsidiaries, viz: UPL Sustainable Agri Solutions Limited (India Crop Protection platform in which UPL holds 90.91 per cent stake); UPL Crop Protection Holdings Limited (Entity through which UPL holds 77.78 per cent stake in its international crop protection business) and UPL Global Sustainable Agri Solutions Limited (Entity to be listed on stock exchanges in which India and international crop protection platforms will be housed post completion of various steps covered in the Scheme). The Scheme will create two listed entities - UPL, an existing listed company as a diversified agriculture and specialty chemicals platform, and UPL Global as a dedicated crop protection platform. The Scheme is subject to the receipt of requisite approvals from the Securities and Exchange Board of India (SEBI), Competition Commission of India (CCI), the Reserve Bank of India (RBI), the Stock Exchanges, the National Company Law Tribunal (NCLT), other statutory and regulatory authorities in and outside India under applicable laws, as well as the shareholders and creditors of the respective companies.

## India-Canada Bilateral Relations: Strengthening Cooperation in Potash and Fertilizer Security



**New Delhi:** Hon'ble Minister of Health and Family Welfare and Chemicals and Fertilizers, Shri JP Nadda, held a meeting with high level Canadian delegation led by Mr. Tim Hodgson, Hon'ble Minister of Natural Resources, Canada in New Delhi on 29th January, 2026. Welcoming the Canadian delegation, Shri Nadda said that strengthening potash availability in India remains central to restoring soil fertility and promoting balanced nutrient application under India's Integrated Nutrient Management framework.

Appreciating Canada's role as a reliable supplier of Muriate of Potash (MOP), Shri Nadda noted that India imports nearly 25% of its total requirement of MOP fertilizer from Canada. He also highlighted Gujarat State Fertilizers and Chemicals Ltd (GSFC) investment of CAD 49.68 million in Karnalyte Resources Inc., a Canadian potash development company. GSFC currently holds a 47.73% equity stake in the project, giving India a substantial strategic share in this important potash asset project. During the deliberations, Mr. Hodgson affirmed Canada's commitment to supporting India's agricultural productivity, noting that potash is a mineral critical for agriculture. He outlined Canada's new investment

environment and conveyed that any investment made by Indian partners in the natural resources sector would be matched by the Canadian government. Both sides also discussed India's long-term strategy for potash security, including opportunities for technical collaboration in mining and exploration and India's interest in securing more long-term supply contracts with Canada for MOP.

The discussions highlighted the shared commitment of India and Canada to enhance collaboration in the fertilizer sector and strengthen the strategic partnership between the two nations for long-term food and agriculture security. Both the countries stand to gain from this initiative which will promote deeper economic cooperation and support mutually beneficial investments in fertilizer sector. ■

### How A.T.E. HUBER is Future-Proofing the Chemical Industry

In today's chemical industry, sustainability is no longer a discretionary initiative but a foundational requirement. Escalating regulatory expectations, heightened public awareness, and growing community sensitivity to environmental contamination have reshaped how chemical manufacturing is evaluated. Managing the environmental impact of processes and by-products is now integral to operational continuity, compliance, and long-term industry credibility.



**A**.T.E. HUBER Envirotech (AHET) views sustainability through the lens of a circular water economy. By shifting the paradigm from waste treatment to resource recovery, the company provides the chemical industry with the technological infrastructure necessary to decouple industrial growth from environmental depletion. Their biological solutions are engineered to ensure that water, the sector's most vital asset, remains a perpetual and dependable resource, securing both operational longevity and ecological integrity; and that sludge is managed safely.

Freshwater is the lifeblood of human existence, agriculture and industry. Yet, in India, this critical resource is under siege. Rapid industrialisation, population growth and the over-extraction of groundwater have created a water crisis that threatens economic ambitions. Careless disposal of wastewater has created soil contamination. As India strives to become a leading global economy, the traditional 'use

and throw' approach to water and unsafe discharge of waste is no longer an option. The future belongs to those who can transform wastewater into a valuable resource.

#### Legacy

AHET is more than a technology provider - it is an embodiment of global engineering excellence operating from India. A joint venture between India's A.T.E. Group, serving Indian industry for over 85 years, and Germany's HUBER SE, a world leader for 180 years, AHET brings together over 200 years of combined wastewater treatment experience.

This partnership bridges the gap between world-class German innovation and deep-rooted Indian engineering expertise. By leveraging HUBER SE's staggering global footprint of 55,000+ installations across 60+ countries, and A.T.E.'s deep Indian roots, AHET provides the Indian chemical and petrochemical sectors with solutions that are both globally proven

**Rapid industrialisation, population growth and the over-extraction of groundwater have created a water crisis that threatens economic ambitions. Careless disposal of wastewater has created soil contamination. As India strives to become a leading global economy, the traditional 'use and throw' approach to water and unsafe discharge of waste is no longer an option. The future belongs to those who can transform wastewater into a valuable resource.**

and locally optimized.

### Impact by the Numbers

The scale of their contribution to the environment is best measured by daily impact. Every single day, AHET systems are responsible for treating 4.8 billion litres of wastewater. This massive volume represents a significant shield against water scarcity, ensuring that growth for AHET's customers does not come at the cost of natural ecosystems.

With more than 300 projects delivered globally, they have established a reputation for successfully executing complex wastewater treatment plants (ETPs) that handle everything from primary and secondary biological treatments to advanced Sludge Management and Zero Liquid Discharge (ZLD).

### The IPADS Approach

In the chemical industry, no two effluent streams are the same. AHET's success lies in its unique IPADS approach, Identifying Pain Areas and Devising Solutions. This methodology ensures that every client receives a tailor-made system designed for their specific wastewater characteristics, resulting in high compliance and high savings.

Appropriate and reliable plants are complemented by value-added products such as bio-boosters, enzymes,

and high-performance cultures to enhance plant performance or restore it after upsets.

### Advanced Technology

Their technological portfolio is designed for high performance operations requiring low intervention:

- Advanced anaerobic and aerobic biological treatment
- HDF® dissolved air flotation for secondary treatment
- Advanced oxidation process
- S Disc® disc thickener for sludge thickening
- Q-Press® screw press for sludge dewatering
- SRT solar active dryer for sludge drying

### Innovation for a Greener Tomorrow

AHET's commitment to sustainability is backed by heavy investment in R&D and pilot trials. By prioritising natural processes, the company reduces chemical consumption and power usage. Their innovative anaerobic processes even provide alternative energy sources like biogas, helping clients like Sudarshan Chemicals, Godavari Biorefineries, Novozymes, Dai-ichi Karkaria, and the Indorama Group reduce their overall carbon and water footprints.

### A Mission Driven by People

While the technology is advanced and relies heavily on automation, the philosophy remains human-centric. As Anuj Bhagwati, Head of A.T.E. Group, says, "At A.T.E. HUBER Envirotech, our foundation is built on the belief that water is not just a resource, but a responsibility. Our approach is shaped by a deep commitment to sustainability and to serving the needs of both people and the planet."

At AHET, growth is viewed as a by-product of a strong value system. From Alkyl Amines to Pidilite and Arkema, AHET's customers are a testament to what happens when deep knowledge and experience come together with a commitment to service. As India moves forward, A.T.E. HUBER Envirotech will continue to be the partner of choice in building a more sustainable and water-secure industrial infrastructure. ■

## Chemtech World Expo 2026: A Resounding Success!

The 32nd edition of International Exhibition & Conferences – Chemtech World Expo 2026 – was successfully held during 3-6 February 2026, at Bombay Exhibition Centre, Goregaon, Mumbai.



**Inauguration of Chemtech 2026 on 3rd February 2026:** (L-R) Dr. Alok Sharma , Director R&D, IOCL & Chairman, Central Advisory Board, Health, Safety & Environment Conference 2026; Mr. Ashwin C Shroff, Executive Chairman, Excel Industries Limited; Mr. B Narayan- Group President Projects & Procurement, Reliance Industries; Mr. Subramanian Sarma; Deputy MD & President, Larsen & Toubro Group; Mr. Artemyev Alexey Yuryevich, Deputy Director of the Department of Chemical Industry of the Ministry of Industry and Trade of the Russian Federation; Mr Maulik Jasubhai, Chairman & Chief Executive, Jasubhai Group & Chemtech Foundation; and Mr. U K Bhattacharya , MD, Steag Energy Services Pvt Ltd, Former Director Projects, NTPC, Core Advisory Committee Member ChemTECH.

Chemtech World Expo 2026 The world meet of the Chemicals, Petrochemicals, Biopharma and Process industry witnessed:

- 700+ Global Exhibitors from 15 countries
- 25,000+ Business Visitors from 50 countries
- 9 Concurrent technical Conferences
- 100+ ClimateTECH Startups (SCALE)
- 1000+ Engineering & Science Students from 56 cities of India (Student Outreach Program)

Concurrent events included focused international exhibition and below 9 technical conferences:

1. Engineering Procurement & Construction
2. Refining & Petrochemicals
3. Specialty Chemicals

4. BioPharma
5. WaterEX
6. Surface Engineering & Corrosion Control
7. Industry Automation & Control and Pumps Valves & Fittings.
8. Agrochemicals & Fertilizers and
9. Health Safety & Environment

The four day tradeshow, succeeded in becoming a catalyst in bringing together the stakeholders from the ecosystem of chemicals processing industry to a common platform and providing unparalleled opportunities to engage, network and explore business opportunities.

*Chemical Engineering World* presents a few snapshots taken during the inaugural day, ie 3rd February 2026.



**Inaugural session of Health Safety & Environment Conference on 3rd February 2026:** (L-R) Mr R K Srivastava , Former Director Exploration , ONGC , Core advisory committee member, ChemTECH; Dr. Alok Sharma , Director R&D, IOCL & Chairman, Central Advisory Board, Health, Safety & Environment Conference 2026; Mr. U K Bhattacharya , MD, Steag Energy Services Pvt Ltd, Former Director Projects, NTPC, Core Advisory Committee Member ChemTECH; Mr. Luc Herwin, Group Head - EHS, Larsen & Toubro and Mr. Rajeev Mathur, Director, HCG Group, Core Advisory committee member, ChemTECH.



**Inaugural Session of Engineering Procurement & Construction Conference on 3rd February 2026:** (L-R) Shri Neeraj Lal, ED-Asset Manager B&S Asset, ONGC; Mr Arvind Kumar, Director (Refineries), Indian Oil Corporation Ltd; Mr. Subramanian Sarma; Deputy MD & President, Larsen & Toubro Group; Mr Maulik Jasubhai, Chairman & Chief Executive, Jasubhai Group & Chemtech Foundation; Mr. B Narayan- Group President Projects & Procurement, Reliance Industries; Mr. Vinayak Pai, MD, Tata Projects and Ms Sukla Mistry, Former Director – Refineries, IOCL & Patron – Refining & Petrochemicals World Expo, ChemTECH.



**Inaugural Session of Specialty Chemicals Conference & Release of Exhibitors Directory on 3rd February 2026:** (L-R) Mr. Zareer Langrana, Former ED & President, Global Chemical Business, Tata Chemicals; Dr Raman Ramachandran, Director & Dean, KJ Somaiya Institute of Management; Mr. Artemyev Alexey Yuryevich, Deputy Director of the Department of Chemical Industry of the Ministry of Industry and Trade of the Russian Federation; Mr. Ashwin C Shroff, Executive Chairman, Excel Industries Limited; and Mr. Rajendra Gogri, CMD, Aarti Industries.



**Inaugural of Student Outreach Program on 3rd February 2026:** (L-R) Mr. Hemant Shetty, CEO, Jasubhai Media & Chemtech Group; Mr R K Srivastava, Former Director Exploration, ONGC, Core advisory committee member, ChemTECH; Prof (Dr.) G D Yadav, President, Indian Chemical Society; Prof (Dr) A B Pandit, Vice Chancellor, ICT - Mumbai and Mr. Rajendra Gogri, CMD, Aarti Industries.



IndianOil Corporation stall at Chemtech 2026



Indo-German Pavilion



GAIL stall at Chemtech 2026



De Dietrich stall at Chemtech 2026



August gathering of delegates during Chemtech 2026 Conference

# UNION BUDGET 2026 - 27

## Union Budget 2026-27: A Sustainable Growth

The Government's proposal in the Union Budget 2026-27 to establish dedicated Chemical Parks represents a forward-looking, infrastructure-led, and supply-side initiative, with a budgetary allocation of ₹600 crore in FY 2026-27. By offering integrated, plug-and-play (ready-to-use) facilities and coordinated governance, these parks are expected to reduce project timelines and costs, foster cluster-based synergies, and create globally competitive chemical manufacturing ecosystems that support sustainable and inclusive growth. *Chemical Engineering World* brings forth industry leaders' opinion about the Union Budget 2026-27 and what it has in store for the chemical industry.



**Abhishek Shrivastava**  
MD, IMEA  
The Lubrizol Corporation

### "This is a forward-looking budget"

"The Union Budget 2026-27 sends a strong and timely signal for India's industrial growth journey. The unmissable focus on domestic manufacturing is reflected through continued support for production ecosystems, infrastructure expansion, and skill development, which will significantly help elevate Indian manufacturing to global standards. For the chemical industry, the government's commitment to rationalising and lowering customs duties on chemical raw materials is particularly important, as it will help reduce costs, strengthen supply chains, and enable Indian manufacturers to compete more equitably at the global level.

Additionally, the focus on logistics and innovation-led growth further reinforces confidence in long-term investments across sectors. The Budget's balanced approach, addressing structural bottlenecks while promoting higher value-added manufacturing supports sustainable growth and resilience. The recent clarity on the GST intermediary ruling also brings much-needed certainty for cross-border services, aiding ease of doing business. Overall, this is a forward-looking budget that aligns industry aspirations with the larger goal of sustainable nation building. Timely and effective execution of the announced measures will be key to unlocking their full impact on businesses and the economy."



**Mahesh Girdhar**  
MD & CEO,

EverEnviro Resource Management Pvt Ltd.

### "Union Budget 2026 marks a defining step in India's gas-based energy transition"

"The Union Budget 2026 marks a defining step in India's gas-based energy transition. The decision to mandate phased blending of Compressed Bio-Gas with CNG and PNG is a systems-level reform that embeds CBG into the mainstream gas ecosystem. The exclusion of the biogas component from central excise duty on biogas-blended CNG significantly improves price competitiveness, while CBG blending delivers clear gains, lower carbon emissions, assured offtake, and stable income opportunities for farmers through agri-residue utilisation. Together, these measures provide the certainty needed to scale renewable gas infrastructure across India."

UNION  
BUDGET  
2026 - 27



**Amitt Nenwani**

Managing Director, Shivtek Spechemi Industries Ltd

**“Announcement of three dedicated chemical parks is a masterstroke”**

“The Union Budget 2026 has provided a definitive blueprint for India’s transition from a chemical consumer to a chemical powerhouse. The Finance Minister’s announcement of three dedicated chemical parks is a masterstroke in de-risking global supply chains and fostering a ‘plug-and-play’ ecosystem for specialty chemicals.

At Shivtek Spechemi Industries Ltd, we have proactively aligned our growth with this vision of self-reliance. Our ₹650 crore expansion plan, which includes our upcoming Chlorinated Polyethylene (CPE) facility, the first of its kind in India, is a direct response to the nation’s massive import dependence on China. By localizing production of critical raw materials like CPE, we are not just building a plant; we are taking a step closer towards creating an innovative ecosystem that allows India to become a leader in specialty chemicals.

The government’s focus on ISM 2.0 and rare-earth corridors further underscores the need for a robust domestic specialty chemical supply chain.

I can humbly state that ‘Aatmanirbharta’ is now meeting industry action. With these new chemical corridors, we expect a significant reduction in logistics costs and a massive surge in R&D-led manufacturing, positioning India as the primary ‘Plus One’ for the global specialty chemicals market.”



**S. Sunil Kumar**

Country President, Henkel Adhesives Technologies

**“The Budget underscores a responsible growth framework”**

“We welcome Union Budget 2026 and its focus on the three *Kartavyas* of accelerating growth, building national capacity, and ensuring inclusive development. The continued emphasis on infrastructure is reflected in the ₹12.2 lakh crore public capital expenditure. Investments in transport corridors, urban infrastructure, capital goods, electronics manufacturing, and semiconductors signal a clear intent to build deeper, more resilient manufacturing capabilities. For the adhesives sector, this supports demand across infrastructure-led and technology-intensive applications. These range from infrastructure and transportation to electronics and semiconductor manufacturing, where performance, durability, and reliability are critical.

Henkel’s strategic focus on innovation, digitalization, and sustainability is well reflected in the Budget’s emphasis on sustainability, digital manufacturing, advanced electronics, and Semiconductor Mission 2.0. The ₹20,000 crore allocation for carbon capture and utilisation further signals that sustainability is being treated as an economic enabler rather than a compliance requirement. Taken together, the Budget underscores a responsible growth framework anchored in inclusivity, capability building and long-term competitiveness, and we would like to credit the government for this.”



**Vishal Sharma**

Executive Director and Chief Executive Officer,  
Godrej Industries (Chemicals)

**“Budget 2026-27 lays out a clear strategy”**

“Budget 2026-27 ramps up the government’s push to make Indian manufacturing stand out, and for the chemicals sector, it’s a strong step forward. Building chemical parks with a plug-and-play setup means local companies can grow faster, depend less on imports, and actually get projects off the ground thanks to better infrastructure and quicker approvals. The reforms around extra funding for research and development is big for chemical sector where progress depends on constant innovation, especially in advanced materials, specialty chemicals, and fresh sustainable solutions. While the budget lays out a clear strategy, the industry would have welcomed stronger fiscal incentives for capital-heavy green tech, quicker clarity on the new labour codes, and more focused support for exports. Moves like these would help chemical companies attract more investment and compete faster on the global stage. Still, the ‘Reform Express’ narrative inspires confidence and provides a solid platform for sustainable, technology-driven manufacturing growth in India.”



**Ketan Kulkarni**

Managing Director & Chief Executive Officer,  
Allcargo Logistics

**“The ₹10,000-crore SME Growth Fund will empower MSMEs”**

“Budget 2026 offers a strategic response to a rapidly changing global trade environment by strengthening India’s logistics and supply chain ecosystem. The focus on multimodal infrastructure including new freight corridors, inland waterways, cargo movement projects and last-mile connectivity for remote regions will be critical in improving efficiency and lowering logistics costs. The ₹10,000-crore SME Growth Fund, supported by enhanced liquidity through mandatory TReDS adoption, credit-backed invoice discounting and GeM integration, will empower MSMEs to scale, formalise and participate more actively in export-led growth. Incentives for indigenous seaplanes and waterway-based cargo movement further unlock regional and alternative logistics pathways. Together, these measures reinforce India’s ambition to remain deeply integrated with global markets, attract long-term investment and build resilient, job-creating enterprises advancing the vision of a Viksit Bharat.”



**Smitha Shetty**

Regional Director, APAC,  
Achilles Information Ltd

**“This is a balanced and forward-looking Budget”**

“Union Budget 2026 reinforces India’s intent to build long-term industrial competitiveness through stronger manufacturing depth and more resilient supply chains. Semiconductors Mission 2.0, dedicated rare earth corridors, and support for domestic chemical clusters reflect a clear focus on reducing import dependency in strategic sectors that are shaping global production systems. The Budget also strengthens MSME growth with meaningful measures such as the ₹10,000 crore SME Growth Fund, additional micro-enterprise risk capital, and reforms that support working capital efficiency through receivables financing and procurement-linked mechanisms. Importantly, the ‘corporate mitras’ initiative can help strengthen compliance readiness without overburdening smaller suppliers, especially in Tier 2 and Tier 3 cities. In an uncertain global trade environment, this is a balanced and forward-looking Budget.”



**Kartik Daftari**

Managing Director & CEO,  
Hi-Tech Radiators Pvt. Ltd

**“This is a budget that translates scale into opportunity”**

“The Union Budget 2026 sends a strong and reassuring signal to industry by placing technology-led manufacturing at the centre of India’s growth strategy. The ₹40,000 crore India Semiconductor Mission 2.0, expanded electronics manufacturing incentives and record capex of ₹12.2 lakh crore will significantly strengthen domestic supply chains and reduce import dependence in critical components. Equally important is the focus on rare earth corridors, chemical and capital goods parks and MSME enablement, which will deepen upstream capabilities and improve export competitiveness. This is a budget that translates scale into opportunity - driving investment, job creation and sustained global relevance for Indian manufacturing.”

**“Budget 2026’s focus is on innovation, skilling, and smart manufacturing”**



**Dr. Bijal Sanghvi**

Managing Director,  
Axis Solutions Limited

“Budget 2026 sets a decisive direction for India’s manufacturing sector by reinforcing the ambition of Viksit Bharat through technology-led, sustainable growth. The emphasis on advanced manufacturing, digital infrastructure, and green initiatives reflects a clear intent to build globally competitive yet responsible enterprises. Digital transformation, driven by IIoT, enables plants to operate with precision and foresight. Integrated plant dashboards, supported by real-time data analytics and continuous monitoring, empower leadership with actionable insights; improving productivity, energy efficiency, and operational resilience. Such capabilities are no longer optional; they are fundamental to achieving scale with consistency and compliance. Sustainability, when combined with data-driven decision-making, ensures long-term value creation for industry, society, and the economy. Budget 2026’s focus on innovation, skilling, and smart manufacturing provides industry leaders the confidence to invest in future-ready plants that are intelligent, transparent, and aligned with India’s journey toward inclusive and enduring industrial progress.”

# “Safety has definitely been on an upward trajectory!”



**Mr. Viraj Shah**  
Founder  
Swa Consultancy Pvt. Ltd.

Ahmedabad-based Firm, Swa Consultancy, is excelling in expert insulation of thermal, acoustic and passive fire safety solutions for industrial and commercial projects. The company is leading the way with strong technical expertise and client-focused design. In an exclusive interview with *Chemical Engineering World*, **Mr. Viraj Shah, Founder, Swa Consultancy Pvt. Ltd.**, shares future growth plans and emphasizes on industry adaptations with respect to fire and safety.



### How has the chemical industry evolved over the years with respect to safety adaptations?

Safety has definitely been on an upward trajectory however, the danger and risks that chemicals bring, the value of human life and efforts for safety, both shall be appreciated.

### How would you describe the highlights of the various products and services offered by Swa Consultancy?

Chemical Industry being one of the highest energy consumers, we offer services to increase energy efficiency by 8-9 per cent through insulation; also increasing safety by using fire safe materials and promoting best practices.

### What are the market trends that the industry has witnessed in the last five years in insulation?

The market has traditionally always been push driven, where the push has been from the manufacturers and vendors to give better solutions currently available in



the industry. So yes, better materials have seen traction but awareness is still lacking among peers.

#### **What role does insulation audits play in maintaining fire and safety norms?**

Whereas Insulation audits are seen more as a tool that decreases energy costs, when fire resistant insulation materials are used, they don't spread the wildfire but rather stop the flame spread and smoke creation. Passive Fire Protection through insulation becomes a big tool for safety.

#### **How would you describe the growth of Swa Consultancy over the years?**

Swa Consultancy is a DPIIT recognized startup

established in 2025. The gap in the domain of Insulation audits has been identified by experienced professionals in the Indian insulation industry, and organizations like EiiF; who are supporting us to grow and develop this market which is practically inexistent in India.

#### **What are the future plans of the company?**

Swa Consultancy wants to contribute in reducing carbon emissions from Indian Industries and contribute towards India's Net Zero targets set in the Paris Convention, and maybe, as big brothers are doing, overachieve it! ■

# Engineering a Complete Power Transmission Ecosystem: Power Build's Full Product Spectrum



Series M



Series C



Series F

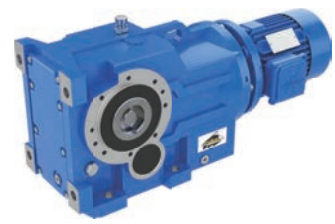

Series K



Series PBWR



Loose Gear



Series A



Series PN



Series J

**P**ower Build has engineered one of the most diverse and powerful portfolios in mechanical power transmission. Built on decades of precision engineering, reliability, and innovation, the company's comprehensive range of geared motors, gearboxes, pumps, and drive systems delivers tailored solutions to industries across the globe.

At the core of Power Build's offerings are the four flagship geared motor series:

**Series M** - Compact Helical Inline Geared Motors delivering up to 160kW and 20,000 Nm torque, ideal for high-efficiency, space-conscious applications.

**Series C** - Right-angled Heli-Worm Geared Motors, combining quiet operation and high torque up to 10,000 Nm, perfect for constrained environments.

**Series F** - Parallel Shaft Mounted Geared Motors with integral torque arms, widely used in material handling and steel industries.

**Series K** - Right-angle Helical Bevel Geared Motors offering up to 50,000 Nm torque, trusted in heavy-duty sectors like cement, power, and mining.

Complementing these are specialized series tailored for unique industrial requirements:

**Series PBWR** - A universal-mount Worm Gear Reducer crafted from aluminium and cast iron, ideal for compact drive solutions with gear ratios up to 100:1.

**Series H** - Hoist-duty geared motors supporting lifting capacities up to 12.5 tons, equipped with crane-specific features and brake options.

**Series PN** - PN Series is a compact yet powerful planetary gearbox solution offering 23 sizes and gear ratios from 3.6:1 to 2250:1. Available in inline and right-angle configurations, it features a wide range of input/output options and mounting styles. Designed for high torque, flexibility, and space efficiency, it's ideal for automation, material handling, and heavy-duty applications. The PN Series reflects PBL's commitment to engineering excellence, durability, and smart power transmission.

**Series A** - Compact, grease-filled geared motors with a small footprint, perfect for light industrial use and available across India through retail partners.

**Series J** - Shaft Mounted Speed Reducers featuring the user-friendly KIBO mounting system, favored in industries like ceramics, paper, and mining.

Further enhancing its product ecosystem, Power Build offers:

**Loose Gears & Pinions** - Manufactured up to DIN Class 6 precision and 1000 mm diameter, supporting customized solutions across sectors like defense, railways, and construction.

**Roloid Gear Pumps** - Rugged and reliable pumps built for lubrication, cooling, fuel, and viscous fluid transfer in complex industrial setups.

**PBL VFD Solutions** - Variable Frequency Drives (up to 400 kW) with built-in high-duty ratings, enabling precise speed, torque, and energy control across all motor products.

This cohesive and wide-ranging product suite positions Power Build not merely as a component supplier, but as a complete transmission partner delivering customized, high-performance solutions that keep industries in motion across the globe. ■

For more details, visit: <http://www.powerbuild.in>

Call: +91-9727719344

# CHEMICAL ENGINEERING WORLD

Dynamic Platform  
to  
Connect with Chemical Industry  
Ecosystem  
Direct Reach  
to  
**>200,000 Readers**  
across  
**>50 countries**  
in **Print** and  
**Digital Version**



Contact: +91-22-4037 3636,  
Email: [sales@jasubhai.com](mailto:sales@jasubhai.com)  
Website: [www.jasubhaimedia.com](http://www.jasubhaimedia.com)



# Durr CTS Innovative Air Abatement Solutions for Chemical and Pharmaceutical Industries

Durr CTS Private Limited based in Pune, India, a wholly owned subsidiary of Dürr CTS GmbH, Germany, is a leading global supplier of air pollution control solutions which includes Regenerative Thermal Oxidizers (RTO), Recuperative Thermal Oxidizers, Direct Fired Thermal Oxidizers along with other innovative applications such as solvent recovery systems. **Mr. Kailash Thakur, Sales Head, Durr CTS Pvt Ltd** through this article, explains in detail about the three solutions and its advantages.

**D**urr CTS products are widely accepted in various end use industries such as chemicals and petrochemicals, pharmaceuticals, tires, flavours and fragrance manufacturing among others. In India, Durr CTS head office is located in Pune, with sales and service offices in Ahmedabad and Chennai.

With more than 60 years of experience in industrial environmental technology, Dürr CTS was formerly part of the Dürr Group. In 2024, Dürr CTS generated annual revenue of more than 400 million euros. Since November 2025, the company has operated independently. Ownership is divided between Stellex Capital Management (75 per cent) and the Dürr Group (25 per cent).

As the emissions arising out from the chemicals and

petrochemicals plants such as particulate matter, SOX, NOX, VOC, acid gases are becoming more complex day by day, choosing the most economical option to control these emissions present several unique challenges. As with any add-on control system, the goal is to minimize the annualized total costs while maintaining proper operation. The types of industrial exhaust streams that present particular pollution-control challenges include:

- Emissions from multiple sources, which are often spread out over a wide area
- Emissions from batch operations
- Unpredictable fugitive emissions

For hydrocarbon emissions, the most commonly applied form of destruction technology is thermal oxidation. In this process, hydrocarbons are converted to carbon dioxide and water vapor at an elevated temperature. Durr CTS Oxi.X product range mentioned below are well suited to handle these types of hydrocarbons:

- Recuperative thermal oxidizers (Oxi.X TR)
- Regenerative thermal oxidizers (Oxi.X RE)
- Direct Fired Thermal Oxidizers (Oxi.X DF) capable of efficiently treating liquid and gas waste streams



Figure 1: Recuperative thermal oxidizers (Oxi.X.TR)

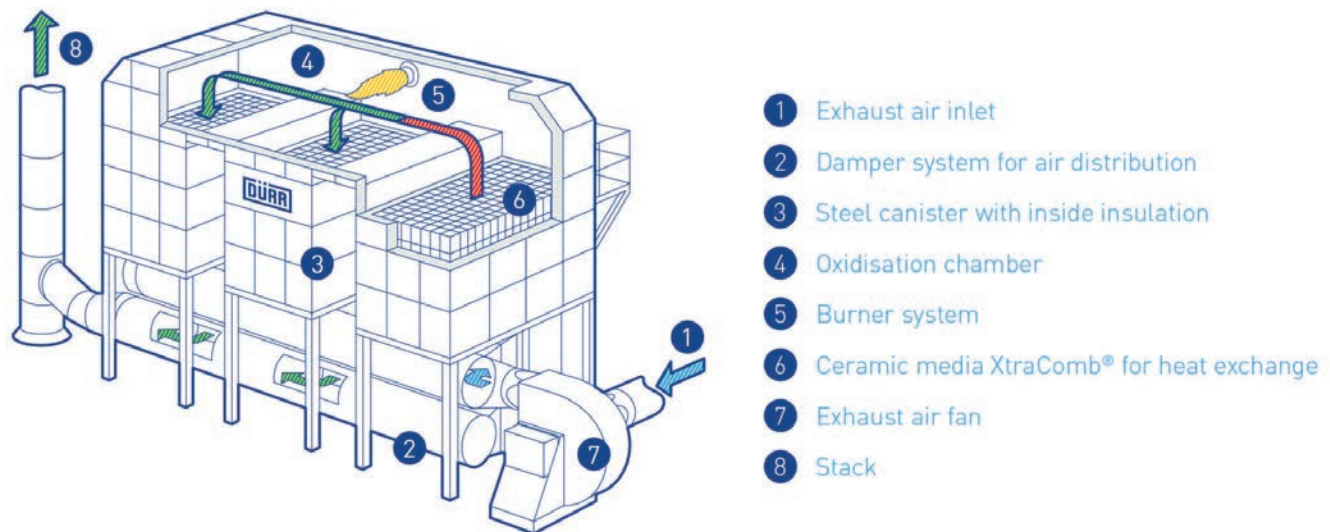

Figure 2: Regenerative thermal oxidizers (Oxi.X.RE)

**Recuperative thermal oxidizers (Oxi.X.TR):** This type of oxidizer includes a combustion chamber with a primary heat exchanger to recover waste heat from the hot incinerated exhaust air and use it to preheat the incoming emissions-laden air stream (Figure 1). These oxidizers typically include a shell-and-tube heat exchanger that are capable of up to 70 per cent primary heat recovery. With an oxidation temperature of about 750°C, such systems often yield sufficient waste heat for secondary heat recovery, even after primary heat recovery. This heat is typically employed for process heating, or to generate steam or hot water. Oxi.X TR are typically best suited for those applications where the excess heat that is generated can be used to offset the relatively high operating (fuel energy) cost for the unit.

**Regenerative thermal oxidizers (Oxi.X.RE):** This type of oxidizer consist of a purification chamber located above separate chambers (generally 3 or more) (Figure 2). These energy-recovery chambers are filled with ceramic heat exchange media. The hydrocarbon-laden air enters the inlet header and is directed to one of the energy-recovery chambers through an inlet control valve. The air passes through the heat exchange media, absorbing heat. It then enters the purification chamber at a temperature very close to the oxidation temperature, typically, 840 to 950°C. If the incoming gas contains sufficient concentration of solvents, the energy content of those organics provides the necessary heat to raise the temperature of the exhaust stream to the combustion set point. The purified air leaves the unit by passing through the heat exchange media in an adjacent chamber. The heat in

the air is transferred temporarily to the heat exchange media. The clean air is discharged through a stack to the atmosphere. The temperature of the air as it leaves the unit is typically only 40-50°C greater than the temperature of the polluted air entering the RTO, signifying good heat recovery and, thus, a very low fuel gas requirement. During operation, multiple chambers of an RTO operate in an alternating sequence, so that at least one chamber is always operating in inlet mode while the second is in outlet mode. The third chamber, necessary for elevated destruction efficiency, is on purge mode.

The advantages of a RTO include very high thermal and destruction efficiency, NO<sub>x</sub> emissions very low as produced by other oxidizers, lower susceptibility to attack from hydrocarbons, and lower overall operating costs. The disadvantages of an RTO include large size (resulting from the need for very large ceramic heat exchange surface), more expensive installation and higher capital cost, and more moving parts. Despite these disadvantages, many features of the RTO make it an ideal technology for the Chemical Process Industry. Multiple emission sources, such as process vents or small batch operations that have been ducted together, can usually be treated with an RTO. Additionally, the RTO can handle a wide range of air volumes, typically as low as 20-25 per cent of design. Generally, recycle capabilities can be installed to ensure that even with reduced inlet flow below 25 per cent of the design, the unit will operate at steady state with continued design destruction efficiencies.

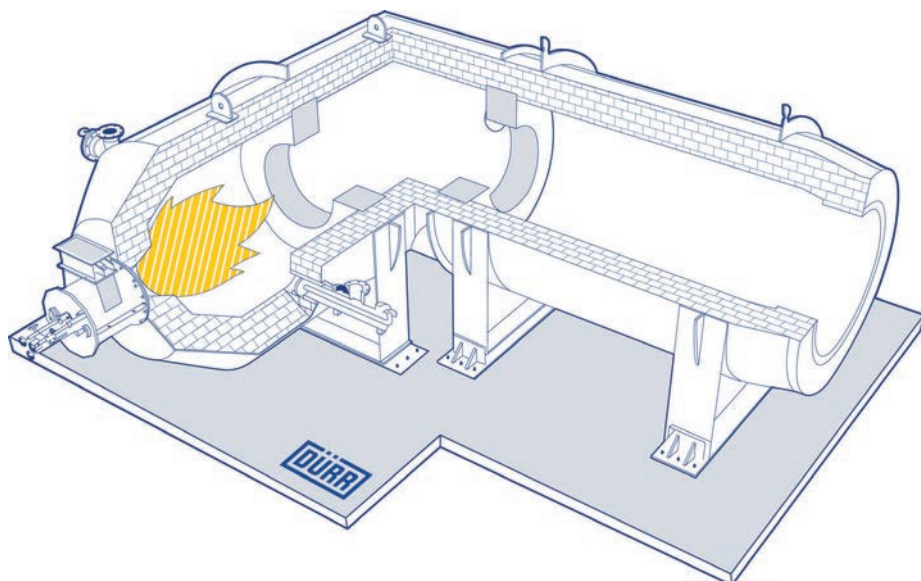

Figure 3: Direct Fired Thermal Oxidizer (Oxi.X DF)

**Direct Fired Thermal Oxidizer (Oxi.X DF)** - This type of oxidizer offers a cost-effective and able method for the treatment of exhaust air or liquids in the chemical, petrochemical and pharmaceutical industries (Figure 3). Because they feature direct combustion with no exchange of air, Oxi.X DF systems normally achieve a destruction efficiency of 99.9 per cent. Typically, such systems are used for:

- Exhaust gases with fluctuating flow rates and pollutant concentrations high enough to be within the explosive range.
- Exhaust gases with an oxygen content of 0-21 vol.%
- Exhaust gases burning only with a backup flame, self-burning lean gases and self-burning rich gases
- Exhaust gases containing halogenated compounds, nitrogen and/or sulfur (this group includes all toxic and carcinogenic substances)
- Residual liquids and waste solvents, plus wastewater with dissolved or emulsified organic and/or inorganic substances difficult to remove.
- Waste and residual liquids that contain or form salts and/or salt-binding substances.

In Oxi.X.DF, the combustion chamber is insulated with a refractory lining and designed to withstand extremely high temperatures. It provides a safe environment in which to oxidize multiple types of gas, liquid and waste pollutants. This combustion chamber and burner form the heart of the system. Generally, Oxi.X.DF system

uses a multi-fuel burner with natural gas or oil as primary fuel source. Liquid and exhaust gas streams are added as auxiliary fuel and oxidized at temperatures ranging between 850 and 1000°C. In an Oxi.X.DF system, all of the liquid wastes, exhaust gases and combustion air are fed into the system through the burner that is located at the back of the combustion chamber. If the waste streams contain very low oxygen levels, the system is specially designed to meet the combustion air requirements for the specific waste streams.

The Oxi.X.DF system has been proven to safely and reliably process exhaust streams laden with extremely difficult or dangerous materials. Numerous add-on enhancements (such as heat recovery), safety devices (such as flame arrestors), water seals, steam generators, NOx-removal systems, lower explosive level (LEL) monitoring, and dilution air injection can also be considered during system design.

A major advantage of the system is its ability to operate at oxygen concentrations as low as 5 per cent, often firing successfully using the waste fuel itself, or with very little support fuel (such as residual liquids or solvents) while simultaneously minimizing the formation of NOx. ■

### Author

**Mr. Kailash Thakur**  
Sales Head  
Durr CTS Pvt. Ltd.

## Showcasing the future of Smart Manufacturing at B&R Innovations Day 2026



Inauguration of India Innovations Day

**B**&R India, the Machine Automation division of ABB, hosted its flagship Innovations Day 2026 in Pune, bringing together customers, OEMs, industry experts, and technology leaders to explore new possibilities that are shaping the future of machine automation and smart manufacturing. A key highlight of the event was the leadership address by Florian Schneeberger, Division President of ABB's Machine Automation division (B&R), who shared a global perspective on the future of machines and intelligent manufacturing eco-systems. This was complemented by insights from India leadership, outlining the region's growth trajectory and the increasing role of advanced automation in enabling competitive manufacturing.

"Innovations Day reflects our continued commitment to empowering manufacturers and machine builders with future-ready automation solutions. By bringing together industry stakeholders on a common platform, we aim to accelerate the adoption of intelligent technologies that drive efficiency, flexibility, and sustainable growth," said Florian Schneeberger, Division President of ABB's Machine Automation division (B&R).

The event also marked the India introduction of ACOPOS D1, B&R's next-generation servo drive, designed to

enable intelligent motion control and scalable machine performance for OEMs.

Through interactive experience zones and expert consultations, attendees gained first-hand exposure to emerging automation technologies tailored to evolving industrial needs across sectors. Innovations Day 2026 underscores B&R India's commitment to strengthening collaboration within the manufacturing ecosystem while advancing digital transformation across industries.

ABB's Machine Automation division delivers automation solutions and services for machine and factory applications across industries such as consumer-packaged goods, printing, life sciences, plastics, energy and maritime. With its B&R's product portfolio, the division delivers integrated control and software, motion control, mechatronics, and machine automation technologies designed to simplify processes and optimize factory operations. ■

# Hindalco announces ₹21,000-crore smelter expansion; commissions FRP and battery foil facilities in Odisha



**Mumbai/Odisha:** Hindalco Industries Ltd, the metals flagship of the Aditya Birla Group, has announced a major expansion of its aluminium operations in Odisha. The company flagged a ₹21,000-crore,

3.6 lakh-tonne-per-annum smelter expansion at its Aditya Aluminium complex in Sambalpur and commissioned a 1.7 lakh-tonne-per-annum Flat Rolled Products (FRP) and battery-grade aluminium foil manufacturing facility with an investment of ₹4,500 crore. The projects were inaugurated by the Hon'ble Chief Minister of Odisha, Shri Mohan Charan Majhi.

These projects are a major step in indigenising critical raw materials for lithium-ion batteries in India, supporting the electric mobility and energy storage ecosystem, while enhancing domestic capabilities in high-grade aluminium products. The battery-grade aluminium foil facility — India's first of its kind — draws input directly from the FRP complex and is designed to support up to 100 GWh of lithium-ion cell manufacturing capacity.

These projects form part of Hindalco's broader growth capital expenditure programme, with around ₹37,000 crore planned for Odisha across upstream and downstream aluminium operations. The Odisha investments are a significant component of the company's overall growth capex of ₹55,000 crore across India.

Hindalco is India's largest flat rolled products player, accounting for over 50 per cent of the domestic market. With nearly 40 per cent of flat-rolled aluminium currently imported into India, the expanded FRP capacity is expected to reduce import dependence by nearly half, supporting domestic manufacturing and improving India's competitiveness in high-grade aluminium products. The smelter expansion at Aditya Aluminium will also mark a step forward in energy transition, with a portion of its power requirement planned to be met through round-the-clock renewable energy (RE-RTC), integrating sustainability considerations into large-scale industrial growth.

Commenting on the development, Mr. Kumar Mangalam Birla, Chairman, Aditya Birla Group, said, "India's manufacturing growth depends on integration, value addition and sustainability. Through Hindalco, we



Hindalco announces ₹21,000-crore smelter expansion; commissions FRP and battery foil facilities in Odisha



Hon'ble Chief Minister of Odisha, Shri Mohan Charan Majhi along with Hindalco Team at the Aditya Aluminium complex in Sambalpur.

are building a fully integrated aluminium ecosystem that spans from upstream resources to high-value downstream products. Our long-standing partnership with Odisha continues to play an important role in this journey. This strategy strengthens India's self-reliance, supports critical sectors, and accelerates the nation's transition towards advanced, sustainable manufacturing."

Mr. Satish Pai, Managing Director, Hindalco Industries Ltd, said, "The FRP expansion and smelter growth at Sambalpur exemplify our integrated upstream-downstream growth strategy. This enables Hindalco to deliver high-quality aluminium solutions across packaging, defence, electric mobility, renewable energy and advanced manufacturing, positioning us strongly to support India's industrial ambitions while creating long-term value."

Hindalco's presence in Odisha spans over 15 years of strong partnership with the State, during which it has already invested more than ₹25,000 crore across bauxite mining, alumina refining, primary aluminium smelting, and downstream manufacturing. The company's operations link upstream resources bauxite, alumina, and primary aluminium with high-value downstream products like FRP and battery foil, creating a fully integrated aluminium ecosystem.

Hindalco's integrated operations currently provide employment to nearly 23,000 people, with the next phase expected to generate over 15,000 additional direct and indirect jobs. The broader investment pipeline includes the FRP and battery foil manufacturing facilities, the primary aluminium smelter expansion, Kansariguda alumina refinery, Meenakshi coal mine, specialised materials such as white fused alumina, and ancillary manufacturing units further consolidating Odisha's status as a national hub for aluminium excellence. ■

# Henkel and Rotary give PoP Ganesha idols a second life through project HARMONY



**H**enkel India, in partnership with the Rotary Club of Navi Mumbai – Joy of Giving and with support from the Navi Mumbai Municipal Corporation (NMMC), has advanced environmental restoration through a high-impact circular reuse initiative under Project HARMONY. The initiative transforms materials from sacred traditions into long-lasting community assets, reinforcing an integrated sustainability approach.

As part of the initiative, materials collected after Ganesh Visarjan 2025 at Nerul were responsibly diverted from land and water bodies and processed through an authorized recycling facility, with on-ground execution supported by NMMC officials. Over 1,000 kg of Plaster of Paris (PoP) was recycled and repurposed into 300 study tables for students at an NMMC school in Digha, creating durable learning infrastructure while preventing environmental pollution.

Launched in 2024, “Henkel and Rotary: Mother Nature & You,” known as Project HARMONY, is Henkel India’s flagship environmental CSR initiative. Built on collaboration and employee volunteering, the program brings together corporate expertise, civic support, and sustainability partners to deliver measurable, on-ground environmental and social impact.

Commenting on the initiative, S. Sunil Kumar, Country President – Henkel India, said, “Project HARMONY reflects our commitment to translating sustainability into tangible outcomes. By converting PoP Ganesha idols into learning assets, we are addressing urban waste challenges through circular, community-led action.”

This initiative was implemented in collaboration with

the renowned Recycle Man of India, Dr. Binish Desai through Pushpam and NuoTerra, using its proprietary PoP recycling technology. Beach Please India supported the collection process through its volunteer network led by Malhar Kalambe. The reclaimed material was processed and converted into learning assets through Pushpam’s women-led, hand-crafted manufacturing under NuoTerra’s process and quality oversight. The initiative respectfully reimagines the lifecycle of materials from sacred Ganesha idols, ensuring environmental responsibility while respecting cultural sensitivities.

Dr. Binish Desai, Founder – NuoTerra, said, “With the right intent and innovation, idol immersion can create lasting value. Responsible recycling ensures devotion continues to benefit society long after the festival.”

The distribution ceremony took place on 22 January 2026 at Rajarshi Chhatrapati Shahu Maharaj Vidyalaya, Rabale, coinciding with Ganesh Jayanti, symbolizing the transformation of devotion into purpose-driven educational support.

Harsh Makol, District Governor 2025–26, Rotary International District 3142, added, “This initiative demonstrates how strong partnerships between Rotary, Henkel, civic authorities, and sustainability partners can collectively address environmental damage and deliver community impact.”

Through Project HARMONY, Henkel India and the Rotary Club of Navi Mumbai – Joy of Giving, along with NMMC and partners, continue to demonstrate how circular solutions and collaboration can build cleaner, more resilient urban ecosystems while supporting community development. ■

## Bridging Bharat & India: How Digital Engineering Solutions are Narrowing Urban-Rural Economic Divide



### Mr. Nagendra Nath Sinha

Managing Director  
Rodic Digital & Advisory

India's economic landscape has long been divided between the globally integrated 'India' of metros and the ambition-fuelled 'Bharat' of smaller towns and villages. Traditional magnets like Mumbai and Bengaluru are ceding ground to Tier-2 cities. The Smart Cities Mission has channelled ₹1.47 lakh crore into connectivity, with improved Tier-2/3 infrastructure potentially contributing \$500 billion to GDP by 2030. Yet growth is hindered by developmental gaps: uneven infrastructure, delayed projects, and fragmented planning. **Mr. Nagendra Nath Sinha, Managing Director, Rodic Digital & Advisory**, through this article, emphasizes on the solution, which is digital engineering, a comprehensive ecosystem spanning physical infrastructure, digital platforms, connectivity networks, and essential services systematically narrowing the urban-rural divide.

**D**igital engineering first narrows the connectivity layer, the base of the divide. BharatNet, the world's largest rural broadband initiative, has laid nearly 6.9 lakh km of optical fiber and connected over 2.18 lakh gram panchayats with high-speed internet, taking broadband into villages for the first time. Common Service Centres and village Wi-Fi hotspots ride on this fiber to offer e-governance, banking, and digital services at the panchayat level, turning connectivity into real access.

The expansion of 4G/5G, satellite internet, and PMWANI village Wi-Fi brings connectivity enabling online purchases, digital transactions, and remote working. This infrastructure reduces the physical distance between Bharat and India for core services like banking, documentation, and welfare.

### Digital Public Infrastructure: The Great Equalizer

Digital Public Infrastructure such as JAM trinity,

DigiLocker, ULPIN, UPI, CoWIN, ONDC brings essential services to rural people. UPI enables small kirana shops, farmers, and daily-wage workers to transact on the same platform as urban businesses. A UN analysis noted that mobile technology with Aadhaar-based ID led to 80% of adults having bank accounts by 2017, reducing gender and education gaps.

Moreover, Aadhaar-linked Direct Benefit Transfers cut leakages, ensuring subsidies reach rural citizens. Digital monitoring of PMAY, Swachh Bharat, Jal Jeevan, and NFSA ensures services reach eligible users. These systems work on basic smartphones, low bandwidth, and multiple languages designed for Bharat's adoption.

### Transforming Service Delivery Through Digital Platforms

Parallely, digitization powers platforms like UMANG, integrating 2,300+ government services in multiple languages. Programs like MGNREGS, PMAY, and PMGSY run on IT platforms, improving transparency. E-learning platforms and PMGDISHA use low-bandwidth apps in local languages. Common Service Centres and similar public services network ensure equity in delivery of a multitude of digital services beyond public services viz. travel, ecommerce, banking, tele-education and telehealth and so on. ONDC-based platforms let farmers and artisans sell beyond local mandis. Mission Bhasini, mandates by BIS to enable vernacular Indic scripts on mobile and other electronic interfaces and work being done by MeITY to bring Indic languages AI models ensure that all Indians, irrespective of their languages can now engage with and contribute to modern IT infospace.

Bridging the healthcare divide, telemedicine solutions built on secure video, electronic health records, and national health platforms like Ayushman Bharat Digital Mission and e-Sanjeevani connect rural patients with urban doctors are reducing the healthcare gap.

A great example is the Bhavya project in Bihar that exemplifies this transformation by implementing a statewide digital platform that tracks healthcare delivery, reveals systemic shortcomings, and enables data-driven policy changes. Live data showing doctors working erratic shifts led to the state government

introducing model roster systems. This is digital engineering transforming not just service delivery, but governance itself.

### Reengineering "Engineering" Through Digital Platforms

While digital platforms provide services, smart physical infrastructure ensures delivery. Traditional planning models are no longer tenable cost overruns reached 20.7 per cent, wasting ₹2.3 lakh crore. Building Information Modelling and Digital Twins transform infrastructure by replacing 2D drawings with integrated 3D models and creating real-time virtual counterparts with live IoT data for predictive maintenance. Computer vision, IOTs, mobile and drone platforms, geospatial frameworks, coupled with AI platforms not only hasten the decision making but also ensure that a variety of data sources contribute to optimal, resource efficient and more objective decision making often beyond capability of ordinary experts.

This ecosystem directly addresses infrastructure challenges through early clash detection, accurate assessments, and continuous monitoring reducing overruns, preventing wastage, and minimizing rework. Critically, it democratizes world-class capability: a ₹2,000 crore metro in Indore can leverage the

**Building Information Modelling and Digital Twins transform infrastructure by replacing 2D drawings with integrated 3D models and creating real-time virtual counterparts with live IoT data for predictive maintenance. Computer vision, IOTs, mobile and drone platforms, geospatial frameworks, coupled with AI platforms not only hasten the decision making but also ensure that a variety of data sources contribute to optimal, resource efficient and more objective decision making often beyond capability of ordinary experts.**

same predictive systems as Mumbai's ₹40,000 crore network, levelling the playing field for Tier-2/3 cities.

However, challenges remain. India has fewer than 15,000 BIM-certified professionals against a need for 200,000. Procurement frameworks favour lowest-cost bidding over lifecycle value. Data standardization needs urgent attention. But these are solvable implementation challenges. The technology exists. Successful pilots exist. What's needed is mandated adoption, standardized protocols, and accelerated talent development.

### The Path Forward: Integration and Scale

India's infrastructure embraces 'Infra 4.0'. Digital Twin applications now span metro networks, airports, expressways, and smart-city utilities, enabling real-time tracking of structural health and operations. BIM has evolved from optional to essential, delivering measurable gains in quality, speed, and cost control.

The nation's ambition to bridge Bharat and India relies not only on capital but on deploying it intelligently across the full digital stack from fiber optic cables and cell towers to payment rails and health platforms, from smart construction to vernacular AI. The question is not whether we can afford this comprehensive digital engineering approach; it's whether we can afford not to.

When a farmer in rural Bihar can access the same digital payment system as a Mumbai trader, when a student in a UP village can attend the same quality online class as her Delhi counterpart, when a patient in Chhattisgarh can consult specialists through telemedicine that's when the economic distance between Bharat and India truly narrows.

Digital engineering, in its fullest sense, is making this vision a measurable reality. Widespread adoption of the same can make India's next development wave both rapid and equitable, bringing opportunity closer to people and narrowing the economic distance between Bharat and India. ■

# CHEMICAL ENGINEERING WORLD

Dynamic Platform  
to  
Connect with Chemical Industry  
Ecosystem  
Direct Reach  
to  
**>200,000 Readers**  
across  
**>50 countries**  
in **Print** and  
**Digital Version**



Contact: +91-22-4037 3636,  
Email: sales@jasubhai.com  
Website: www.jasubhaimedia.com



## Vacuum Technology for Chemical and Pharmaceutical Processes



### **Ms. Meike Strasheim**

Head of Market Management Content Strategy  
Pfeiffer Vacuum+Fab Solutions

Vacuum technology is an essential element of chemical and pharmaceutical manufacturing. It enables key operations such as distillation, drying, conveying, and inerting, by providing process conditions that would be difficult or impossible to achieve under ambient pressure. Through this article, **Ms. Meike Strasheim, Head of Market Management Content Strategy, Pfeiffer Vacuum+Fab Solutions**, provides an in-depth comparison of conventional and dry vacuum pump technologies, with a focus on dry screw vacuum pumps. It further aims to provide process engineers and plant designers with the insights needed to specify and design vacuum systems that meet today's technical, regulatory, and economic demands.



## IMPACT FEATURE



Figure 1: This image shows a model from the DOLPHIN series by Busch, known for its robustness and suitability in vapor-laden and particle-rich environments. Source: Busch Group.

Vacuum requirements vary significantly across chemical processes, depending on factors such as volatility, process temperature, gas composition, and contamination sensitivity. Different vacuum technologies offer distinct advantages and trade-offs. Understanding the operating principles of each vacuum pump type is key to selecting the right solution for a given application.

### Liquid Ring Vacuum Pumps

Liquid ring vacuum pumps operate using an impeller mounted off-center that rotates within a partially filled chamber. The liquid – typically water or a compatible solvent, forms a ring along the chamber wall due to centrifugal force. As the impeller rotates, it traps gas between the liquid ring and the impeller blades, compressing it as the chamber volume decreases. The liquid absorbs heat from compression and acts as a sealant, keeping internal temperatures low and reducing the risk of ignition.

These vacuum pumps are valued for their simplicity, robustness, and ability to handle saturated vapors as well as small particles. However, their achievable vacuum is relatively low (typically limited to ~33 hPa [mbar] absolute, depending on the liquid used and its corresponding vapor pressure). They are also less energy-efficient compared to dry technologies and require a continuous supply of operating fluid, which adds to utility and maintenance costs.

### Rotary Vane Vacuum Pumps

Rotary vane vacuum pumps consist of a rotor mounted off-center in a cylindrical housing. As the rotor turns, vanes actuated by centrifugal force slide out to create sealed compression chambers. Gas is drawn into the expanding volume and expelled under compression as the chamber contracts. These vacuum pumps rely on oil for sealing, lubrication, and cooling – either through a closed loop system or a once-through configuration to handle chemically active or condensable media.

Rotary vane vacuum pumps are compact, easy to install, and widely used in general applications. In chemical and pharmaceutical settings, single-stage vacuum pumps are most common due to their robustness and simplicity.



Figure 2: Cross-sectional view of an R5 single-stage rotary vane vacuum pump. Source: Busch Group.

While versatile, these vacuum pumps are susceptible to oil contamination and degradation if oil is reused in a closed loop system. In continuous operation, the oil condition must be monitored, replaced regularly, and

# IMPACT FEATURE

filtered properly to avoid process interference. Their typical vacuum range spans from 100 to 1 hPa (mbar) in single-stage versions, with dual-stage configurations reaching  $10^{-3}$  hPa (mbar) when properly maintained and operated under optimal conditions.

## Dry Screw Vacuum Pumps

Dry screw vacuum pumps use two interlocking screw-shaped rotors that compress gas with no contact between the moving parts or operating fluid in the process chamber. As the rotors turn in opposite directions, gas is trapped between the twin screws and the housing, progressively compressed, and discharged. This oil-free design eliminates contamination risk, making the vacuum pumps ideal for processes involving solvents, reactive compounds, or clean environments.

They can achieve vacuum levels around  $10^{-2}$  hPa (mbar) and are well-suited for clean, reactive, or solvent-rich environments. Their performance depends on precise thermal control to avoid condensation or polymerization, especially when operating with volatile process gases. Their higher initial investment is justified by long service intervals, low total cost of ownership, and high reliability under challenging conditions.

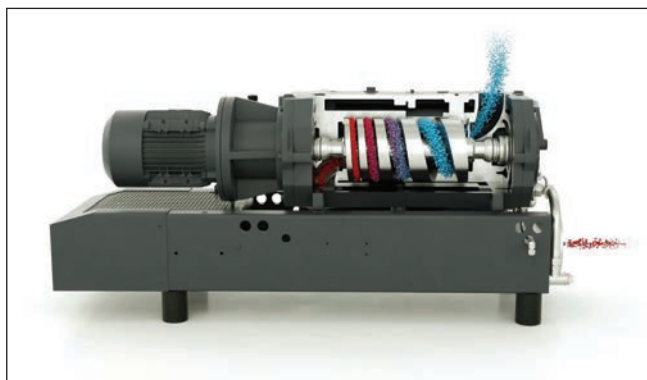

Figure 3: Cutaway view of a dry screw vacuum pump showing the internal rotor geometry. Source: Busch Group.

## Design Considerations for Vacuum Systems

Designing a reliable and efficient vacuum system extends far beyond choosing the suitable vacuum pump technology. It involves careful coordination of multiple factors, ranging from process conditions and material compatibility to layout constraints and automation strategies.



Figure 4: Custom-engineered vacuum system with PANDA and PUMA vacuum boosters as the first stage and COBRA screw vacuum pumps as backing pumps Source: Busch Group.

## Process Chemistry and Material Selection

The chemical composition of the process stream – especially the presence of condensables, corrosives, or reactive gases – dictates material selection and sealing technology. Stainless steel is a standard baseline for wetted components, but more aggressive environments may require specialized coatings, alloys like Hastelloy or titanium, or non-metallic materials such as PTFE. For dynamic sealing surfaces, especially around rotating shafts, double mechanical seals or magnetically coupled drives for leak-free operation might be needed.

Choosing suitable O-ring and gasket materials, such as FFKM or EPDM, is critical to prevent degradation when exposed to acids, solvents, or elevated temperatures.

## System Resistance and Pressure Drop

Every valve, filter, bend, and restriction between the process and the vacuum pump introduces pressure losses. In low-pressure systems, even small pressure drops can significantly affect performance or lead to undersizing the vacuum pump. Therefore, a pressure drop analysis of the complete system from chamber or reactor to pumping unit should be part of the early engineering phase.

## Thermal Management

Thermal control is crucial in vacuum systems, especially for dry screw vacuum pumps handling condensable or polymerizable vapors. The vacuum pump body must be kept warm enough to prevent internal condensation but below thermal material and safety limits. This is

typically managed through heating jackets, cooling loops, and gas-ballast systems.

In processes involving solvent-rich streams, controlling the inlet piping temperature and pre-heating during startup helps prevent sticky deposits that may compromise rotor clearance or cause corrosion. A pre-condenser can also be a solution, allowing a reduction in the amount of chemicals reaching the pumping unit.

## Layout and Integration

Space constraints often dictate the form factor of the system, especially in retrofit projects. Skid-mounted, modular designs allow tighter footprints and easier maintenance access. Vertical stacking and wall-mounted control panels can help reclaim floor space. Systems must also be accessible for cleaning, inspection, and potential part replacement without requiring full disassembly.

Compliance with local safety regulations, especially in ATEX zones, will influence enclosure design, ventilation strategy, and component certifications.

## Automation and Control

Vacuum systems increasingly integrate with DCS (Distributed Control Systems) or PLCs (Programmable Logic Controllers) to support advanced process control and diagnostics. Parameters such as inlet pressure, motor current, cooling flow, and seal integrity can be monitored in real time. In high-value processes, this supports predictive maintenance, early fault detection, and compliance tracking.

Modern systems use controlled valves and frequency-controlled motors to dynamically adjust vacuum generation to the process load, reducing energy consumption and mechanical stress.

## Operational Challenges of Vacuum Systems

One of the most common and impactful issues is the condensation of vapors within the vacuum pump. When condensable gases fall below their dew point during compression, they can liquefy inside the vacuum pump, leading to corrosion, internal fouling, or – in severe cases – hydraulic shock. The risk is highest in dry vacuum pumps, where there are no internal

liquids to buffer phase transitions.

Related to this is the challenge of improper startup and shutdown sequences. If a vacuum pump is brought online while still cold, condensable vapors may condense immediately upon contact with internal surfaces. Similarly, stopping a process without removing residual vapors can result in unwanted deposition or corrosion during cooldown.

Another persistent challenge involves the ingress of solids and particulate matter. Dry screw vacuum pumps are especially sensitive due to their tight internal clearances. Even small amounts of powders, sticky residues, or abrasive crystals can accelerate wear or reduce compression efficiency. In processes where dust or condensable slugs are present, the vacuum pump's performance and longevity may be compromised if no pre-separation or filtration system is installed.

Maintenance presents its own set of operational concerns. While dry vacuum pumps generally offer longer service intervals, the consequences of unexpected failure are often severe. Unmonitored shifts in power draw, temperature, or vibration can signal early-stage issues that, if ignored, lead to costly repairs and unplanned downtime.

## Protection Strategies and System Accessories

To ensure vacuum systems remain reliable and efficient in chemically and thermally demanding environments, protection strategies must be thoughtfully designed and implemented.

Thermal stability is one of the key prerequisites for preventing internal condensation and phase-related damage. In processes involving solvents or reactive vapors, the vacuum pump body and associated piping must be maintained above the dew point of the gases involved. This is often achieved through external heating systems or thermal jackets. Gas-ballast valves are commonly used to dilute condensable vapors, reducing the likelihood of phase change within the compression chamber.

Contaminant ingress is another major threat to vacuum equipment, particularly in systems handling solids,

## IMPACT FEATURE

slurries, or dusty environments. Effective filtration is essential to keep abrasive or reactive materials from entering sensitive components. Depending on the process, protection may involve fine-mesh inlet screens for large particulates, high-efficiency filters for fine powders, or knock-out pots and cyclonic separators to remove droplets and slugs from vapor streams.

Corrosion resistance begins with material selection. Vacuum pumps and piping in contact with aggressive media must be made from chemically compatible materials. Stainless steel 316L is often used as a default in pharmaceutical settings, while more aggressive chemistries may require Hastelloy, titanium, or additional surface treatments such as PTFE or ceramic coatings. Elastomeric components such as seals and gaskets should be carefully matched to the media in question, with materials like FFKM, EPDM, or fluoroelastomers used depending on chemical resistance requirements.

Sealing performance plays a critical role in both environmental protection and regulatory compliance. Static seals must maintain integrity under pressure and temperature cycles, while dynamic seals – especially around rotating shafts – must ensure gas tightness without compromising mechanical efficiency. Double mechanical seals and magnetically coupled drives are frequently used in systems where leakage is unacceptable. For ultra-clean environments or processes involving toxic gases, bellows seals and encapsulated drives offer added layers of containment. These sealing strategies are often selected with compliance frameworks such as ATEX, TA Luft, or regional emissions regulations in mind.

Protective components can also support recovery and sustainability goals. Condensers positioned upstream of the vacuum pump can capture valuable solvents, reduce vapor load, and improve overall system economy. Cold traps are similarly used to recover hazardous or condensable vapors. The effectiveness of these systems depends on correct sizing and specification, including parameters such as condenser temperature, system pressure drop, and expected recovery volumes.

Finally, system protection is greatly enhanced by

intelligent monitoring and control. Sensor networks tracking pressure, temperature, vibration, and motor current can detect early signs of wear or instability. When integrated with plant automation systems, these inputs allow for automated shutdowns, maintenance alerts, and process adjustments in real time. Advanced data analytics tools further enable predictive diagnostics and long-term performance optimization.

### Conclusion

Vacuum systems are more than peripheral utilities – they are critical enablers of process performance, product quality, and plant safety in the chemical and pharmaceutical industries. As regulatory standards tighten and expectations grow around sustainability, digitalization, and operational transparency, vacuum technology must evolve in both capability and complexity.

While established solutions like liquid ring vacuum pumps and steam ejectors continue to serve high-load or rugged applications, the industry's shift toward dry, oil-free technologies – particularly dry screw vacuum pumps – reflects a growing demand for clean operation, minimal maintenance, and seamless integration into automated process environments.

But selecting the right vacuum solution is more than achieving a target pressure. It requires a comprehensive understanding of the gases involved, thermal behavior, contamination risks, system layout, and utility infrastructure. Long-term success hinges on marrying the correct vacuum pump technology with effective safeguards, intelligent control systems, and well-structured operating procedures. ■

Supported by



# World Meet of the **CHEMICALS, PETROCHEMICALS, BIOPHARMA & PROCESS** Industry in India



33<sup>rd</sup> International Exhibition & Conferences

February-March 2028

Venue: Bombay Exhibition Center, Goregaon (East), Mumbai, India

Announcing

## Concurrent Events



### Scope for ChemTECH World Expo

- Plant Machinery & Industrial Consumables
- Engineering Consultants
- OEMs for Chemicals & Pharmaceutical Processing Equipment
- Metals & Metallurgy
- Bioprocessing Equipment
- Construction Services Providers
- Plant Maintenance Services Providers
- Logistics & Supply Chain Solutions Providers
- Instrumentation & Process Control
- Industry Automation (Process & Factory)
- Systems Integration & ERP Solutions Providers
- Water & Waste Water Treatment Consultants
- Environment Solutions Providers
- Waste Management Consultants
- Financial Institutions
- Fire & Safety Solutions Providers
- Material Handling Solutions
- Certification Bodies
- Welding Solutions
- Quality Health & Environment Solutions
- Analytical & Laboratory
- Packaging Materials, Machinery & Systems
- Business Consultants

### Scope for Biopharma World Expo

- Materials Processing
- Pharma Machinery
- Pharma Ingredients
- Plant Engineering, Process Plants & Equipment
- Laboratory & Analytical Solutions
- Process Measurement & Inspection
- Sterilization & Clean Room Solutions
- Biopharma R&D And Manufacturing
- IT Solutions
- Water & Waste Treatment Solutions

### Scope for Specialty Chemicals World Expo

- Agrochemicals Intermediates
- Adhesives & Sealants
- Agrochemicals & Crop Protection
- Bulk Drugs & Intermediates
- Enzymes
- Colorants, Dyes & Pigments
- Cosmetics & Personal Care Ingredients
- Hygiene & Cleaning Chemicals
- Laboratory Chemicals
- Surfactants
- Water Treatment Chemicals
- Catalysts
- Electronic Chemicals
- Flavours & Fragrances
- Contract Manufacturers

## HIGHLIGHTS OF CHEMTECH WORLD EXPO 2026

<b>800+</b> EXHIBITORS FROM 15+ COUNTRIES	<b>26000+</b> VISITORS FROM 50+ COUNTRIES
<b>9</b> TECHNICAL CONFERENCES	<b>1500+</b> BUSINESS DELEGATES
<b>250+</b> GLOBAL SPEAKERS	<b>100+ GLOBAL CLIMATE TECH STARTUPS</b>
<b>1200+</b> ENGINEERING PHARMA & SCIENCE STUDENTS AT STUDENT OUTREACH PROGRAM FROM 28 STATES & UNION TERRITORIES	<b>40 TECHNICAL PRESENTATIONS</b> FROM 20 COUNTRIES

Organised by:



## Jasubhai Media Pvt Ltd

Taj Building, 3<sup>rd</sup> Floor, 210, Dr. D N Road, Fort, Mumbai – 400 001, INDIA.

Tel: +91-22-4037 3636, Email: sales@jasubhai.com

Ahmedabad - 09833104834 | Bangalore - 09892644177 | Chennai - 09176963737

Delhi - 09891469629 | Hyderabad / Pune - 09822209183 | Vadodara - 09820544904

sales@jasubhai.com

www.chemtech-online.com

[www.dipflon.com](http://www.dipflon.com)

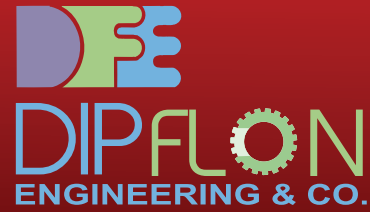

## SHIELDING AGAINST CORROSION

Quality is never an accident it is always the result of  
High Intention, Sincere Effort, Intelligent Direction  
and Skillful Execution.



### PFA/FEP/PVDF/PP LINED VALVES



### PFA/FEP/PVDF/PP LINED FITTINGS



### PTFE LINED SPOOL PIPES & PIPE FITTINGS



## DIP-FLON ENGINEERING & CO.

Factory : Plot No. 803/804 & 1002/1003, Phase-II, G.I.D.C., Industrial Estate, Chhatral - 382 729, Dist : Gandhinagar, Gujarat.

Ph.: +91-2764-234232 | M.: +91 98987 94440, +91 99244 99948

Office : B-413, B. G. Towers, Near Delhi Darwaja, Shahibaug Road, Ahmedabad-380 004. Gujarat. India.

Ph. : +91-79-2562 4003, 2562 4169 | M. : +91 98987 94440 / +91 92276 84378 | E-mail : [info@dipflon.com](mailto:info@dipflon.com), [sales@dipflon.com](mailto:sales@dipflon.com)